

Inshore Gulf of Maine Acoustic Survey of Atlantic Herring Sentinel Spawning Grounds

Final Report: July 1, 2005 through June 30, 2007



CONTRACT NO. NA05NMF4721057

AMOUNT OF CONTRACT: \$192,919

SUBMITTED TO:

Northeast Consortium, University of New Hampshire
142 Morse Hall, 39 College Rd
Durham, NH 03824

PREPARED BY:

Daniel Salerno
Collaborative Research Technician
Gulf of Maine Research Institute

DATE SUBMITTED:

July 2007



SUBMITTED BY:

John Annala, Chief Scientific Officer
Gulf of Maine Research Institute
350 Commercial St
207-228-1621, jannala@gmri.org

Table of Contents

Abstract	1
Introduction	2
Objective	4
Participants	5
Methods		
Survey Design	6
Data Collection Systems	6
Biological Sampling	7
Sub Areas	8
Target Strength Calculation	9
Biomass Estimation	10
Data	11
Results / Conclusions		
Survey Design / Biological Sample Collection	12
Leg 1	12
Leg 2	13
Leg 3	13
Leg 4	13
Leg 5	13
Leg 6	14
Leg 7	14
Herring Distribution	14
Spawning Stage Analysis	14
Comparison with Historical Spawning	15
Sub Areas / Calculated Target Strengths	15
Biomass Estimation	16
Biomass Estimates by Maturity Stage	17
Prespawning Biomass	17
Spawning Biomass	17
Post Spawning Biomass	17
Literature Cited	19
Partnerships	22
Impacts / Implications	23
Presentations	24
Future Research	25

List of Tables

Table 1. Dates for each leg of the acoustic survey	6
Table 2. FEMTO 75 kHz transducer specifications	7
Table 3. ICNAF Atlantic herring gonad development stages	8
Table 4. Total area covered and number of successful tows where Atlantic herring were caught by survey leg	12
Table 5. Sub area for each leg and their respective size and calculated target strength used for total biomass estimates	15

List of Figures

Figure 1. Atlantic herring spawning sites within the Gulf of Maine and Bay of Fundy	26
Figure 2. U.S. Atlantic herring fishery management areas	27
Figure 3. Generalized coverage of past GMRI acoustic surveys for Atlantic herring in the Gulf of Maine	28
Figure 4. Study area for 2006 acoustic survey of Atlantic herring	29
Figure 5. Vessel trackline utilized in the acoustic survey	30
Figure 6. F/V Jennifer & Emily	31
Figure 7a. Net diagram of midwater trawl used in acoustic survey, upper and lower panel	32
Figure 7b. Net diagram of midwater trawl used in acoustic survey, side panel	33
Figure 8. Survey transect coverage for Leg 1, August 21 – 26	34
Figure 9. Total Atlantic herring distribution for Leg 1, August 21 – 26	35
Figure 10. Survey transect coverage for Leg 2, September 5 – 10	36
Figure 11. Total Atlantic herring distribution for Leg 2, September 5 – 10	37
Figure 12. Survey transect coverage for Leg 3, September 18 – 23	38
Figure 13. Total Atlantic herring distribution for Leg 3, September 18 – 23	39
Figure 14. Survey transect coverage for Leg 4, October 2 – 7	40
Figure 15. Total Atlantic herring distribution for Leg 4, October 2 – 7	41
Figure 16. Survey transect coverage for Leg 5, October 16 – 20	42
Figure 17. Total Atlantic herring distribution for Leg 5, October 16 – 20	43
Figure 18. Survey transect coverage for Leg 6, October 23 – 28	44
Figure 19. Total Atlantic herring distribution for Leg 6, October 23 – 28	45
Figure 20. Survey transect coverage for Leg 7, October 30 – November 3	46
Figure 21. Total Atlantic herring distribution for Leg 7, October 30 – November 3	47
Figure 22. Percent spawning stage for Atlantic herring by leg	48

Figure 23. Sub areas used for total biomass estimate of Leg 1	49
Figure 24. Sub areas used for total biomass estimate of Leg 2	50
Figure 25. Sub areas used for total biomass estimate of Leg 3	51
Figure 26. Sub areas used for total biomass estimate of Leg 4	52
Figure 27. Sub areas used for total biomass estimate of Leg 5	53
Figure 28. Sub areas used for total biomass estimate of Leg 6	54
Figure 29. Sub areas used for total biomass estimate of Leg 7	55
Figure 30. Length frequency distribution of Atlantic herring by sub area for Leg 1	56
Figure 31. Length frequency distribution of Atlantic herring by sub area for Leg 2	57
Figure 32. Length frequency distribution of Atlantic herring by sub area for Leg 3	58
Figure 33. Length frequency distribution of Atlantic herring by sub area for Leg 4	59
Figure 34. Length frequency distribution of Atlantic herring by sub area for Leg 5	60
Figure 35. Length frequency distribution of Atlantic herring by sub area for Leg 6	61
Figure 36. Length frequency distribution of Atlantic herring by sub area for Leg 7	62
Figure 37. Total Atlantic herring biomass estimates for each survey leg	63
Figure 38. Atlantic herring biomass by adult maturity stage for each survey leg	64
Figure 39. Percentage of total biomass by adult maturity stage for each survey leg	65

ABSTRACT

Atlantic herring is an ecologically and commercially important fish species found in the Northwest Atlantic Ocean. In US waters, spawning occurs for this species in the Gulf of Maine and on Georges Bank. Recent population assessments indicate the Gulf of Maine area comprises approximately 18% of the stock biomass. Historically, the herring fishery has focused its activities in the coastal portion of the Gulf of Maine (management area 1A). As recently as 2004, 64% of the landings have come from this area. This high catch rate has led to concern about the persistence of historically major spawning grounds and the need for better information relevant to these areas in the Gulf of Maine.

In response, the Gulf of Maine Research Institute conducted an acoustic survey to monitor the location, timing and biomass levels of prespawning and spawning aggregations of Atlantic herring on Jeffreys Ledge and the associated nearshore area. Seven systematic parallel transect surveys were conducted between late August and early November 2006. Acoustic data was collected using a FEMTO Electronics Limited DE9320 Digital Echosounder interfaced with a 75 kHz hull mounted transducer. Fish aggregations were sampled with a midwater trawl net to confirm species identification and to collect biological samples.

Herring were seen in all portions of the study area during most of the survey except on the northern portion of Jeffreys Ledge where no fish were encountered. Total biomass levels remained relatively low (8974 – 33,095 mt) from August through the end of October but increased three fold (99,488 mt) in early November. Prespawning biomass was highest in late August and early September and then dropped to nothing at the end of October. Spawning herring were first encountered in mid-September. Spawning biomass peaked in mid-October and dropped dramatically through early November.

This survey was able to capture the complete spawning event. However, the low biomass levels encountered indicate that the area surveyed was not a key area for Atlantic herring spawning in 2006.

INTRODUCTION

The Atlantic herring, *Clupea harengus*, is a pelagic, schooling species found throughout the North Atlantic Ocean (Stevenson and Scott, 2005). In the western Atlantic it ranges from Labrador southward to Cape Hatteras, inhabiting coastal and continental shelf waters (ASMFC, 2004). In New England and the Canadian Maritimes, herring is a commercially important species that is used for human consumption and bait for the American lobster fishery. Herring is also an important forage species, providing a crucial trophic link between zooplankton and larger fish in the Gulf of Maine ecosystem (Tupper et al., 1998).

There are three separate stock components based on spawning along the northeast coast of North America: Southwest Nova Scotia / Bay of Fundy, coastal waters of the Gulf of Maine, and Georges Bank / Nantucket Shoals (Overholtz et al., 2004). Spawning occurs primarily in the summer and fall months of the year. The onset occurs in the northeast, beginning at the head of the Bay of Fundy and proceeds in a westerly direction along the coasts of Nova Scotia / New Brunswick / Maine / New Hampshire / Massachusetts and ends on Georges Bank (Tupper et al., 1998) (Figure 1).

In US waters, herring are assessed and managed as a single stock unit with two distinct spawning components: Gulf of Maine and Georges Bank / Nantucket Shoals (Stevenson and Scott, 2005). The Gulf of Maine stock component biomass is estimated as a proportion of the total biomass calculated from the overall stock assessment model, with no direct estimate of biomass or biomass trend available (Overholtz et al., 2004). Minimum population estimates of the two spawning areas indicate that the Gulf of Maine area comprises approximately 18% of the stock complex biomass (TRAC, 2006). Given the information provided by the stock assessment of the complex, total allowable catches (TAC) are set for four different management areas. Historically, the highest landings have been reported from area 1A (Figure 2), which is primarily in coastal waters (Overholtz et al., 2004). As a result, the highest proportion (~64% in 2004) of the total catch is from the smallest component of the Gulf of Maine/Georges Bank complex (ASMFC, 2006).

The high rate of catch in management area 1A has led to concern about the persistence of historically major spawning grounds. Population rich species such as Atlantic herring have a number of separate spawning grounds throughout their range (Smedbol and Stephenson, 2001; Stephenson et al., 1999). The preservation of within species diversity is of increasing importance to scientists (Stephenson and Kenchington, 2000). The maintenance of a diverse population structure may allow populations to better adapt to environmental and human disturbances (Smedbol and Stephenson, 2001; Stephenson et al., 2001). Smedbol and Stephenson (2001) argue that the spatial structure of a population gives it resilience and adaptability, and therefore should be of importance to the short-term management of commercially exploited fish species

In recent years, federal stock assessment scientists, state management scientists, fishing industry members, and conservation groups have voiced a need for better information

relevant to the portion of the stock that spawns along the Maine, New Hampshire, and northern Massachusetts coasts during the fall months. The National Marine Fishery Service conducts an annual acoustic survey of the offshore (Georges Bank and Nantucket Shoals) spawning component but does not extend coverage to the inshore spawning beds.

The Gulf of Maine Research Institute (GMRI) has studied the temporal and spatial characteristics of herring aggregations resident in Gulf of Maine waters using acoustics on commercial fishing vessels since 1998. Annual broad-scale surveys have been conducted resulting in a nearly continuous coverage from Eastern Maine to Cape Ann, Massachusetts (Figure 3). The program has attempted to estimate the biomass of herring spawning in these waters during the fall months to establish an index of spawning stock biomass.

An independent panel of fisheries and acoustics scientists reviewed all previous acoustic work conducted by GMRI in March 2005. The panel concluded that acoustic surveys are generally considered to be the survey of choice for herring, and recommended that this technique be continued in the inshore Gulf of Maine due to the lack of knowledge about the timing and locations of the significant spawning events for herring in this region. The panel also recommended developing a monitoring project to identify the key areas where Atlantic herring spawn in the nearshore and inshore waters of the Gulf of Maine and also suggested the survey use a more focused “sentinel survey” approach as opposed to a broad scale survey.

OBJECTIVE

Following from the peer review recommendations, this project was designed to acoustically monitor the locations, timing, and biomass levels of prespawning and spawning aggregations of Atlantic herring on significant “sentinel” spawning grounds. The western portion of the Gulf of Maine (Figure 4), which encompasses Jeffreys Ledge, Scantum Basin, and the coastal waters from Cape Ann, MA to Cape Porpoise, ME was chosen for a trial of this sentinel survey approach. The long-term goal is to extend the sentinel survey model to additional areas in the nearshore Gulf of Maine. Specific information collected on the timing and locations of spawning Atlantic herring will allow comparison with historical distributions and abundance of spawning Atlantic herring and provide insight into the relative importance of this region for spawning Atlantic herring.

PARTICIPANTS

Dr. John Annala, Project Leader
Gulf of Maine Research Institute
350 Commercial Street
Portland, Maine 04101
(207) 228-1621
jannala@gmri.org

Daniel Salerno
Vessel & Data Technician
Gulf of Maine Research Institute
350 Commercial Street
Portland, Maine 04101
(207) 228-1671
dsalerno@gmri.org

Shale Rosen
Vessel & Data Technician
Gulf of Maine Research Institute
350 Commercial Street
Portland, Maine 04101
(207) 228-1635
srosen@gmri.org

Dr. Matthew Cieri,
Management/Regulatory Partner
Maine Department of Marine Resources
PO Box 8
West Boothbay Harbor, Maine 04575
(207) 633-9520
matthew.cieri@state.me.us

Captain Mark Bichrest, Vessel Owner
F/V Jennifer & Emily
16 Winthrop Farm Road
Harpwell, Maine 04079
(207) 729-4810

Captain Lendell Alexander
F/V Jennifer & Emily
307 Cundys Harbor Road
Harpwell, Maine 04079

Captain Alden Leeman, III,
F/V Jennifer & Emily
10 Gurnet Landing Road
Harpwell, Maine 04079

Dr. Patrick Sullivan, Project Advisor
Cornell University
Department of Natural Resources
214 Fernow Hall
Ithaca, New York 14853
(607) 255-8213
pjs31@cornell.edu

METHODS

Survey Design – Temporal

Six sets of 5 night-long survey legs were originally planned to be conducted between late August and early November. This time period was chosen to ensure the survey covered the timing of peak spawning for Atlantic herring. In the Gulf of Maine, spawning has been reported to occur between August and December with a peak in September and October (O'Brien et al., 1993). An additional survey leg (for a total of seven) was incorporated to ensure surveys encapsulated the entire period of spawning (Table 1). Surveys were conducted at night, when herring are off bottom, can be detected acoustically and easily sampled with a midwater trawl net.

Leg #	Dates
1	August 21 – 26, 2006
2	September 5- 10, 2006
3	September 18 – 23, 2006
4	October 2 – 7, 2006
5	October 16 – 20, 2006
6	October 23 – 28, 2006
7	October 30 – November 3, 2006

Table 1. Dates for each leg of the acoustic survey.

Survey Design – Spatial

A discrete systematic parallel transect design was employed to cover Jeffreys Ledge, Scantum Basin, and the inshore waters from Cape Ann, MA to Cape Porpoise, ME. The vessel trackline (Figure 5) used to accomplish each survey period was 421 nautical miles (nm) and covered an area of approximately 900 nm² (3000 km²). The distance between transect lines was set at 2.5 nm. This spacing was selected in order to ensure a complete survey could be conducted over the course of five days, taking into account length of nighttime hours, vessel speed and anticipated time spent collecting biological samples with a midwater trawl.

Data Collection Systems

At sea data collection for this study was accomplished with a commercial fishing vessel provided by Margaret F, Inc. The F/V Jennifer & Emily (Federal Permit No. 330448, Coast Guard Doc. No. 619778) (Figure 6) of Cundys Harbor, ME is a steel midwater and groundfish stern trawler approximately 63' in length. The vessel was outfitted with a 17 x 15 fm midwater trawl net with a 1⁷/₈" mesh codend (Figure 7a & 7b). The net included a trawl monitoring system which relayed real time height of headrope from the sea bottom to aid with the collection of herring samples.

Data on herring abundance and distribution was collected using a FEMTO Electronics Limited DE9320 Digital Echosounder interfaced with a 75 kHz hull mounted transducer and a general purpose PC for data logging. Table 2 displays the specifications for the FEMTO 75 kHz transducer. Calibration of the system was carried out using the ball calibration technique outlined in Scheirer et al. (2005a) and Yund (2000). This was done twice, once before and once after the survey was conducted.

75 kHz Transducer Specifications:	
Beam Angle	9.8
2-way Equivalent Ideal Beam	-17.7 dB
Power (Kw RMS) 2% duty	2.0
Beam Pattern	Conical
PZT Elements	19
Impedance (Ohms Nominal)	70
Insertion Loss	-10 dB
Transmitting Response	172 dB
Receiving Sensitivity	-182 dB
Q (Transmit Nominal)	6

Table 2. Femto 75 kHz transducer specifications.

Physical and biological oceanographic data were continuously collected at the surface along survey transects and at depth using two Sea Bird CTD units. Surface data was collected by running a deck hose into an upright wooden box holding the CTD. Depth cast were made at the start of each night as well as after tows where herring was collected.

Biological Sampling

When significant aggregations of fish were detected acoustically, the midwater trawl was set to confirm species identity and to collect approximately 100 individual Atlantic herring. Tows were conducted along the transect line after passing over the fish aggregations. Tow times were generally short in duration (10 – 20 minutes); just long enough to collect the necessary samples. All herring samples were frozen at sea for further laboratory analysis.

Back in the laboratory, herring samples were thawed out for examination. Natural length measurements were taken to the nearest 5 mm, total weight to the nearest 0.1 g, gonad weight to the nearest 0.1 g, sex and International Commission for the Northwest Atlantic Fisheries (ICNAF) gonad development stage (Table 3). In order to account for freezing

and thawing of herring samples, length measurements were corrected using Maine Department of Marine Resources' correction equation:

$$L_{\text{mm}} = 4.1825 + 1.0051 * [\text{Frozen Sample Length (mm)}].$$

Stage	Description and Criteria
I	Immature: testes and ovaries very small, threadlike, 2 – 3 mm broad; testes grayish white or brownish red; ovaries pinkish or wine red.
II	Immature fish that will spawn next year: testes and ovaries small, 3 – 8 mm broad; testes reddish or grayish brown; ovaries orange-red; eggs visible only with microscope.
III	Ripening, early stage: testes and ovaries occupy about half of ventral cavity, 1 – 2 cm broad; testes grayish or brownish red; ovaries orange-red; eggs small, but visible and granular.
IV	Ripening, mid-stage: testes and ovaries almost as long as body cavity; testes reddish yellow with blood vessels clearly visible; ovaries orange-red or pale yellow-red; eggs larger, opaque with only a few clear.
V	Ripe: testes and ovaries fill body cavity; milt and eggs do not flow, but can be extruded by pressure; testes yellowish white or milk white with no reddish color and blood vessels not visible; ovaries yellowish; eggs large and mostly clear.
VI	Spawning: testes and ovaries ripe and emptying; milt and eggs flow freely; testes white or pale yellowish white with no blood vessels visible; ovaries yellowish; eggs large and clear.
VII	Spent: testes and ovaries baggy, flabby and bloodshot; testes empty or with residual milt; ovaries empty or with few residual eggs.
VIII	Resting: testes and ovaries firm and larger than in Stage II; walls striated with blood vessels prominent; testes brownish red; ovaries wine red; eggs not visible to naked eye.

Table 3. ICNAF Atlantic herring gonad development stages (from Burnett et al., 1989).

Sub Areas

Each survey leg was apportioned into geographical sub areas prior to data analysis in order to allow for more precise target strength calculations for individual aggregations of fish. For any given leg, the observed distribution of Atlantic herring as well as the locations and distribution of biological sample tows were used to define between two and four unique sub areas for the leg. Data from all biological sample tows conducted within a given sub area were combined before calculating a target strength. This process should reduce the variance within each sub area biomass estimate and accounted for multiple sampling of the same fish aggregations.

Target Strength Calculations

The target strength (TS) equation :

$$TS = 20 \text{ Log } (L) - b$$

was utilized for calculating TS for Atlantic herring in this study. The intercept from Foote (1987) of -71.9 dB was used; however, a correction factor was employed because this intercept is calculated from 38 kHz (see below).

The corrected frozen length and weight data recorded from the collected herring samples were plotted in an xy scatter chart using Microsoft Excel and a non-linear regression line (power equation) was fitted to the data. The coefficients a and b from the regression equation:

$$Y = aX^{(b)}$$

were used in the length/weight equation:

$$W_{5\text{mm}}(\text{kg}) = aL_{5\text{mm}}^{(b)}$$

where a is the y intercept and b is the slope of the line to calculate an individual weight for each 5 mm length bin. The weight (kg) and length (cm) were then used to calculate a TS (dB/kg) value for each length bin using the equation:

$$TS_{5\text{mm}} (\text{dB/kg}) = \{20 * \text{Log}(L_{5\text{mm}}/10) - 71.9\} - \{10 * \text{Log}(W_{5\text{mm}})\}.$$

The resultant values for each length bin were made linear by:

$$\text{Linear } TS_{5\text{mm}} (\text{dB/kg}) = 10^{(TS/10)}.$$

This value was then multiplied by the number of fish (n) in each length bin to calculate a weighted TS for each 5 mm length bin:

$$\text{Weighted Linear } TS_{5\text{mm}} (\text{dB/kg}) = n_{5\text{mm}} * \text{Linear } TS_{5\text{mm}}.$$

Separate TS values were calculated for each 5 mm length bin in order to account for any samples with non-normal length distributions. In these cases, such as a bimodal distribution, mean length would not accurately describe the sample. By calculating TS for each length bin and weighting by the percentage each bin contributed to the total sample, a weighted mean TS was calculated for the sample:

$$\text{Weighted Mean Linear } TS (\text{dB/kg}) = \sum (\text{Weighted Linear } TS_{5\text{mm}})/N.$$

Next, the weighted mean linear TS was converted back to log scale to give the weighted mean TS:

Weighted Mean TS (dB/kg) = 10 * LOG(Weighted Mean Linear TS)

This provided the weighted mean TS in dB/Kg at 38 kHz. Since the transducer used in this survey was 75 kHz, the TS was then corrected for the frequency difference using Love's equation (1971):

$$TS(F) = 0.9 * \log_{10}(38\text{kHz}/F\text{kHz}).$$

For 75 kHz data, -0.26575 dB was added to the 38 kHz TS.

Biomass Estimation

Acoustic data editing, processing and biomass estimates were performed using HydroAcoustic Data Processing System (HDPS) software developed by FEMTO Electronics Limited. HDPS performs data editing and processing on a step by step basis with user defined inputs to compute biomass estimates. Detailed instructions for using HDPS can be found in Scheirer et al. (2005a & 2005b).

DATA

Three sets of data files are included with this report to be posted on the Northeast Consortium's Fisheries and Oceans Database:

1. CTD cast data: These files include the cruise or leg number, cast number, date, time, latitude, longitude, depth (m), temperature (°C), salinity (ppt) and fluorescence (mg/m³).
2. Survey transect data – These files include ping number, year, month, day, time, latitude and longitude.
3. Herring biological sample data – These files include date, time, latitude, longitude, length (mm), weight (g), sex, ICNAF maturity stage and gonad weight (g).

The raw acoustic data files will not be submitted since it can only be interpreted by users with specialized analysis software. GMRI is presently aware of only two other groups that possess the software necessary to view the data collected, both part of the Canadian Department of Fisheries and Oceans. The data are therefore unsuitable for posting on a general access database such as the Northeast Consortium's Fisheries and Oceans Database.

A technical problem was encountered while collecting the CTD surface data files. No date or time was recorded; therefore, they can not be matched to any positions from the survey transect data. These files will not be submitted.

RESULTS / CONCLUSIONS

Survey Design / Biological Sample Collection

A total of seven survey legs were conducted starting in late August and ending in early November. Table 4 displays the approximate total area covered and the number of successful sample tows where Atlantic herring was captured for each leg of the survey.

Leg #	Total Area Surveyed (km ²)	Number of Tows
Leg 1	3095	0
Leg 2	2767	5
Leg 3	2970	4
Leg 4	2916	5
Leg 5	2895	2
Leg 6	2976	7
Leg 7	2932	7

Table 4. Total area covered and number of successful tows where Atlantic herring were caught by survey leg.

The midwater trawl net proved to be an excellent gear for sampling herring when conditions allowed for deployment of the gear. Large amounts of fixed gear and extremely shallow depths in the coastal region hindered sampling efforts on some of the inshore transects. As a result, the full extent of the inshore aggregations was likely under sampled.

The following is a synopsis of the survey track and biological sampling results for each survey leg:

Leg 1 (August 21 – 26)

The transect coverage for Leg 1 is shown in Figure 8. This leg had two additional transects completed off the northern tip of Jeffreys Ledge. These were dropped in subsequent legs due to excessive depth. Figure 9 displays the distribution of fish observed during Leg 1. Fish were detected in relatively low amounts on the middle of Jeffreys Ledge and in most of the inshore region; however, no biological samples were

collected for this leg because of the low abundance on Jeffreys Ledge and shallow depths and fixed gear encountered in the inshore region.

Leg 2 (September 5 – 10)

Figure 10 displays the transect coverage for Leg 2. Two transects on the northern portion of the inshore area were not completed due to excessive sea conditions (sea state 3 – 4) which greatly diminish the accuracy of the acoustical equipment. The distribution of fish for this leg (Figure 11) shows that there was a greater presence of fish on middle to lower Jeffreys Ledge and more fish distributed throughout the inshore region. Three biological samples were collected on Jeffreys Ledge and two samples collected inshore. Biological sampling indicated that the majority of these fish were in the prespawning stage (ICNAF Stage III & IV) with some juveniles (ICNAF Stage I & II) mixed in for all areas sampled.

Leg 3 (September 18 – 23)

Leg 3 transect coverage is displayed in Figure 12. All proposed transects were completed for this leg. The distribution plot (Figure 13) indicates aggregations of herring on middle to lower Jeffreys Ledge and in the northern portion of the inshore area. Three biological samples were collected on Jeffreys Ledge and one sample from the inshore region. Biological sampling for this leg still showed a predominance of prespawning fish in all tows. Spawning herring (ICNAF Stage V & VI) began to appear in this time period at all towed locations. Tow location 1 had the largest percentage of ICNAF Stage VI fish. A few post spawning fish (ICNAF Stage VII & VIII) were also seen at this location.

Leg 4 (October 2 – 7)

Figure 14 displays the transect coverage for Leg 4. One transect off the northern tip of Jeffreys Ledge was not completed due to a miscommunication between the vessel captain and field technician. The distribution of fish in Leg 4 (Figure 15) showed aggregations of herring on the lower half of Jeffreys Ledge and the lower two-thirds of the inshore region. Two samples of herring were collected from Jeffreys Ledge and three from the inshore strata. Sampling from Leg 4 indicated a mix of all spawning stages at all sample sites. Overall, there was a decrease in the amount of prespawning fish (ICNAF Stage III & IV) and an increase in post spawning fish (ICNAF Stage VII & VIII). Spawning fish (ICNAF Stage V & VI) percentage remained about the same as the previous leg. Juvenile herring (ICNAF Stage I & II) were seen in greater amounts along the inshore area than in the offshore area.

Leg 5 (October 16 – 20)

Leg 5 transect coverage is displayed in Figure 16. All proposed transects were completed for this leg. Figure 17 shows the distribution of herring was concentrated along the inshore region of the strata. Small amounts were also observed on Jeffreys Ledge. One biological sample was collected from both Jeffreys Ledge and the inshore area. The fish sampled on Jeffreys Ledge were mostly spawning fish (ICNAF Stage V & VI) with a few

post spawning fish (ICNAF Stage VII & VIII) mixed in. The inshore sample was made up of mostly post spawning fish (ICNAF Stage VII & VIII).

Leg 6 (October 23 – 28)

Figure 18 displays the transect coverage for Leg 6. All proposed transects were completed for this leg. The distribution of herring in Leg 6 (Figure 19) showed fish along the lower half of Jeffreys Ledge and all along the inshore area. Three samples were collected on Jeffreys Ledge and four from the inshore area. Fish collected from all areas were mostly juvenile (ICNAF Stage I & II) and post spawning (ICNAF Stage VII & VIII) fish. A minimal amount of spawning (ICNAF Stage V & VI) fish was caught at sample tow location 3.

Leg 7 (October 30 – November 3)

Transect coverage for Leg 7 is displayed in Figure 20. All proposed transects were completed for this leg. Figure 21 displays the distribution of herring for Leg 7. Herring were detected along the inshore area and on the lower portion of Jeffreys Ledge. Five samples were collected inshore, while only 2 samples were collected on Jeffreys Ledge. Biological sampling showed similar results to the previous leg, most of the fish were juvenile (ICNAF Stage I & II) and post spawning (ICNAF Stage VII & VIII) fish. A minimal amount of spawning fish (ICNAF Stage V & VI) were found at sample tow location 5.

Herring Distribution

Aggregations of Atlantic herring were encountered in most areas of the survey strata in all seven legs. However, herring were never observed on the northern portion of Jeffreys Ledge. The distribution of Atlantic herring on Jeffreys Ledge and the inshore waters of the western Gulf of Maine has previously been well documented by various federal and state bottom trawl surveys (Stevenson and Scott, 2005). The lack of fish detected on the northern portion of Jeffreys Ledge appears to be consistent with recent results from the NMFS/Northeast Fisheries Science Center (NESFC) Autumn Bottom Trawl Survey (Overholtz et al., 2004). Results from the 2006 NMFS/NEFSC Atlantic Herring Acoustic Survey also showed minimal amounts of fish on the northern portion of Jeffreys Ledge (NOAA, 2006).

Spawning Stage Analysis

Analysis of herring gonad staging data (Figure 22) indicates that the timing of the survey encapsulated spawning in the study area. Spawning was first encountered in mid-September (Leg 3) with 24% of the sampled fish in spawning stage (ICNAF Stage V & VI). In Leg 4, at the beginning of October, 25.5% of the herring were in spawning stage. Peak spawning for the entire survey strata was seen in mid-October (Leg 5) with 47.2% of fish observed to be in ICNAF Stage V & VI. Thereafter, a dramatic decrease in

spawning activity was observed with just 0.2% of the herring in spawning stage from late October through early November (Legs 6 & 7).

Comparison with Historical Spawning

Atlantic herring spawning in the Gulf of Maine has been reported since the late 19th century (Earll, 1887; Moore, 1898). This study documented spawning on Jeffreys Ledge from New Scantum southward to the “base” of Jeffreys Ledge off Cape Ann. Sampling from this survey did not show any spawning north of New Scantum. Spawning on Jeffreys Ledge was first described in detail in the 1970’s by Boyar et al. (1973) and Cooper et al. (1975). Boyar et al (1973) went as far as hypothesizing that spawning events from Jeffreys Ledge resulted in a major source of recruitment to the coastal Maine herring fishery.

On the inshore portion of the survey area, in Ipswich Bay, the GMRI acoustic survey recorded spawning from Boon Island southward past the Isles of Shoals to the mouth of the Merrimack River. No spawning was observed from Boon Island north to Cape Porpoise. The spawning seen in this portion of the survey appeared to be of a lesser extent than that seen on Jeffreys Ledge. Historically, spawning along the coast has been reported in Bigelow and Schroeder (1953) along the beaches of the western Gulf of Maine in Ipswich Bay around Cape Ann. Tupper et al. (1998) reports herring spawning around the Isles of Shoals.

Sub Area / Calculated Target Strengths

Table 5 describes the sub areas, their respective size and calculated target strength used for total biomass estimations. Figures 23 – 29 illustrates the sub areas used for total biomass estimate of each leg. The number of sub areas and sizes vary between survey legs due to the variable distributions of herring and locations of biological sample collection sites.

Leg #	Sub Area	Area (km ²)	Target Strength (dB)
Leg 1	Jeffreys	1662.84	-35.220
	Northern Inshore	688.09	-35.279
	Southern Inshore	743.66	-35.170
Leg 2	Northern Jeffreys	964.48	-35.547
	Southern Jeffreys	478.54	-35.115
	Northern Inshore	583.94	-35.279
	Southern Inshore	739.69	-35.170
Leg 3	Northern Jeffreys	1268.87	-35.349
	Southern Jeffreys	300.76	-34.612
	Inshore	1400.76	-35.164
Leg 4	Northern Jeffreys	1013.56	-35.494
	Southern Jeffreys	328.08	-35.618
	Northern Inshore	781.44	-35.426
	Southern Inshore	793.13	-35.025

Leg 5	Jeffreys	1653.41	-35.503
	Inshore	1241.86	-34.869
Leg 6	Northern Jeffreys	1008.04	-35.013
	Southern Jeffreys	678.39	-34.758
	Northern Inshore	709.91	-34.379
	Southern Inshore	579.73	-34.930
Leg 7	Jeffreys	1438.03	-34.771
	Northern Inshore	608.33	-33.992
	Southern Inshore	813.47	-35.031

Table 5. Sub area for each leg and their respective size and calculated target strength used for total biomass estimates.

Atlantic herring target strength were calculated using length measurements collected from the biological samples. Biological samples collected within each sub area were aggregated to produce length frequency distributions for each sub area by survey leg (Figures 30 – 36). Since no biological samples were available for Leg 1, samples collected in Leg 2 were used as a proxy for calculating target strengths for Leg 1 sub areas.

Biomass Estimation

Figure 37 displays the total biomass estimates calculated using HDPS. The first six survey legs show relatively low levels of total Atlantic herring biomass. In late August (Leg 1), total herring biomass was approximately 25,000 metric tons (mt). A decreasing trend in biomass levels was seen through mid-September (Leg 3) to a minimum of ~9,000 mt. Thereafter, biomass levels increased modestly to ~33,000 mt by the end of October (Leg 6). A dramatic increase (~300%) in biomass was seen the following week (Leg 7) with a biomass estimate of ~99,500 mt.

The data indicate that the western Gulf of Maine was not a key spawning area for Atlantic herring in 2006. Given that the TAC for the management area 1A was set at 60,000 mt for the 2006 fishing year (NEFMC/NMFS, 2006) and the western Gulf of Maine is only a portion of this management area, it does not seem feasible that the biomass levels calculated through the first six legs of the survey could support the fishery. Although there is no direct evidence from this study, it is hypothesized that the majority of the Gulf of Maine spawning complex was located in the midcoast and eastern portions of coastal Maine. This theory is supported by the following:

1. The increase in total biomass in early November (Leg 7) can be attributed to a significant influx fish that spawned outside the study area (see below).
2. Tagging studies summarized in Tupper et al. (1998) illustrate herring migrate through the present study area after spawning on the midcoast and eastern spawning grounds off the Maine coast.

3. One of the acoustic survey vessel captains indicated that two weeks prior to Leg 7, large concentrations of Atlantic herring were detected on his echo sounder further “downeast” off the Maine coast (Captain Alden Leeman III, personal communication).

Biomass Estimates By Maturity Stage

Biomass estimates by maturity stage were accomplished by partitioning total biomass estimates by observed ICNAF spawning stage percentages. Figure 38 displays the estimated biomass levels by maturity stage.

Prespawning Biomass (ICNAF Stage III & IV)

Prespawning biomass levels were highest at the beginning of the survey in late August and early September, estimated at 18,179 and 15,932 mt respectively, and then showed declines through the next four legs to a minimum of 140 mt in mid-October. By late October and early November, no prespawning fish were recorded from the biological samples.

Spawning Biomass (ICNAF Stage V & VI)

Spawning fish were first recorded in mid-September (Leg 3). Relatively modest levels of biomass were seen in mid-September and early October, estimated at 2,157 and 2,515 mt respectively. By mid-October, spawning biomass jumped to 13,057 mt. The following two weeks showed a dramatic decline in spawning biomass, to 54 and 152 mt in late October and early November respectively.

Post Spawning Biomass (ICNAF Stage VII & VIII)

Post spawning fish were first recorded in mid-September in a minimal amount (25 mt). The following three legs showed increasing biomass levels to 22,966 mt in late October. In early November, a dramatic increase was seen in post spawning biomass levels, to 77,498 mt.

Figure 39 illustrates the changes in percent biomass for these three spawning categories. The pattern observed for Atlantic herring in this study is expected when monitoring an assemblage of fish throughout a spawning event. Prior to the event, the majority of the fish are in the prespawning or “developing” phase. As the spawning episode begins, the percentage of prespawning fish should decrease to zero as these fish become active spawning fish. The percentage of spawning or ripe fish will increase until peak spawning is achieved, after which the percentage decreases as only remnants of the population continue to spawn. Following spawning, these fish will enter the post spawning or “spent” phase where the percentage will increase as more fish spend out their milt and eggs.

Actively spawning Atlantic herring were possibly undersampled during this survey. Atlantic herring spawn on the ocean bottom (Stevenson and Scott, 2005) and a midwater trawl by design does not contact the bottom. Therefore, the capture of actively spawning herring with this gear is possible but not probable. If this situation did indeed occur, the biomass estimation for spawning fish would be underestimated.

However, it is believed that the three fold increase of post spawned fish from late October to early November is not a result of undersampling of spawning fish. Atlantic herring have been shown to disperse from spawning sites very soon after egg deposition (Stevens and Knowles, 1988) and migration studies indicate that herring from the midcoast and eastern regions of Maine move through the study area after spawning to their wintering grounds in the southwest portion of the Gulf of Maine and south of Cape Cod (Stevenson and Scott, 2005). While it is not known where the large amount of post spawned fish observed by this study came from, biomass levels seem to indicate that they did not originate from the western Gulf of Maine region.

Vessel avoidance behavior by herring can be a problem when conducting acoustic surveys and can lead to underestimation of biomass, especially in shallow water where vessel noise does not dissipate quickly (Johannesson and Mitson, 1983). Vessel avoidance by herring has been documented in the past by Olsen (1979) and Vabø et al. (1998). It would be difficult to know whether or not vessel avoidance was an issue in this survey because the FEMTO system has only a single downward facing beam which only gives a two dimensional view directly under the vessel. Recent advances in sonar and acoustics have led to three dimensional mapping using multibeam sonar and are being used to quantify vessel avoidance behavior in pelagic species (Mayer et al., 2002). It would be useful to employ this technique in future surveys to measure / account for any avoidance behavior.

LITERATURE CITED

- ASMFC. 2004. Species Profile: Atlantic Herring. New ASMFC & NEFMC Amendments to Increase Protection of Inshore Stocks. Atlantic States Marine Fisheries Commission. Washington, D.C.
- ASMFC. 2006. 2005 Review of the Fishery Management Plan for Atlantic Sea Herring (*Clupea harengus harengus*). Atlantic States Marine Fisheries Commission. Washington, D.C.
- Bigelow, H.B. and W.C. Schroeder. 1953. Fishes of the Gulf of Maine. U.S. Fish. Wild. Serv. Fish. Bull. 74:88-100.
- Boyar, H.C., R.A Cooper and R.A. Clifford. 1973. A study of the spawning and early life history of the herring (*Clupea harengus harengus* L.) on Jeffreys Ledge in 1972. ICNAF Res. Doc. 73/96.
- Burnett, J., L. O'Brien, R.K. Mayo, J.A. Darde and M. Bohan. 1989. Finfish Maturity Sampling and Classification Schemes Used during Northeast Fisheries Center Bottom Trawl Surveys, 1963-89. NOAA Technical Memorandum NMFS-F/NEC-76.
- Cooper, R.A., J.R. Uzmann, R.A. Clifford and K.J. Pecci. 1975. Direct observations of herring (*Clupea harengus harengus* L.) egg beds on Jeffreys Ledge, Gulf of Maine in 1974. ICNAF Res. Doc. 75/93.
- Earll, R.E. 1887. The herring fishery and the sardine industry. Goode, G.B., ed. The Fisheries and Fishery Industries of the United States. US Government; Sec 5(1): pp. 417-542.
- Foote, K.G. 1987. Fish target strengths for use in echo integrator surveys. J. Acoust. Soc. Am. 82:981-987.
- Johannesson, K.A and R.B. Mitson. 1983. Fisheries acoustics. A practical manual for aquatic biomass estimation. FAO Fisheries Technical Paper 240.
- Love, R.H. 1971. Dorsal-aspect target strength of an individual fish. J. Acoust. Soc. Am. 49(3):816-823.
- Mayer, L.A., Y. Li and G. Melvin. 2002. 3D visualization for pelagic fisheries research and assessment. ICES Journal of Marine Science. 59:216-225.
- Moore, H.F. 1898. Observations on the herring and herring fisheries of the northeast coast, with special reference to the vicinity of Passamaquoddy Bay. US Fish Comm. Rep. Wash., Govt. Print Off.: US Fish Comm.: Report of Comm. For year ending June 30, 1896, Part XXII. pp. 387-442.

New England Fishery Management Council and National Marine Fisheries Service. 2006. Fisheries of the Northeastern United States; Atlantic Herring Fishery; 2006 Specifications.

NOAA. 2006. Cruise Results: Cruise DE 06-15 (Parts I – III) – Atlantic Herring Acoustic Survey. NMFS/Northeast Fisheries Science Center. Woods Hole, MA.

O'Brien, L., J. Burnett and R.K. Mayo. 1993. Maturation of nineteen species of finfish off the Northeast Coast of the United States, 1985 – 1990. NOAA Technical Report NMFS 113.

Olsen, K. 1979. Observed avoidance behavior in herring in relation to passage of an echo survey vessel. ICES C.M. 1979/B:18:10 p.

Overholtz, W.J., L.D. Jacobson, G.D. Melvin, M. Cieri, M. Power, D. Libby and K. Clark. 2004. Stock assessment of the Gulf of Maine - Georges Bank Atlantic herring complex, 2003. Northeast Fisheries Science Center Reference Document 04-06.

Scheirer, K., S. Rosen and A. Clay. 2005a. The Fishery Independent Hydroacoustic Survey of Inshore Gulf of Maine Atlantic Herring: 1999-2004 Final Report. Gulf of Maine Research Institute. Portland, Maine.

Scheirer, K., S. Rosen and A. Clay. 2005b. Appendices to: The Fishery Independent Hydroacoustic Survey of Inshore Gulf of Maine Atlantic Herring: 1999-2004 Final Report. Gulf of Maine Research Institute. Portland, Maine.

Smedbol, R.K. and R. Stephenson. 2001. The importance of managing within-species diversity in cod and herring fisheries of the north-western Atlantic. Journal of Fish Biology 59 (Supplement A): 109 – 128.

Stephenson, R. L., K.J. Clark, M.J. Power, F.J. Fife and G.D. Melvin. 2001. Herring stock structure, stock discreteness, and biodiversity. In: F. Funk, J. Blackburn, D. Hay, A.J. Paul, R. Stephenson, R. Toresen, and D. Witherell (eds.). 2001. Herring: Expectations for a new millennium. University of Alaska Sea Grant, AK-SG-01-04, Fairbanks, Alaska. 559-571 p.

Stephenson, R. L. and E. Kenchington. 2000. Conserving fish stock structure is a critical aspect of preserving biodiversity. ICES C.M. 2000/Mini: 07.

Stephenson, R. L., K. Rodman, D.G. Aldous and D.E. Lane. 1999. An in –season approach to management under uncertainty: the case of the SW Nova Scotia herring fishery. ICES Journal of Marine Science. 56: 1005 – 1013.

Stevenson, D.K. and M.L. Scott. 2005. Essential Fish Habitat Source Document: Atlantic Herring, *Clupea harengus*, Life History and Habitat Characteristics. 2nd ed. NOAA Technical Memorandum NMFS-NE-192.

TRAC. 2006. Gulf of Maine – Georges Bank Herring Stock Complex. TRAC Status Report 2006/01.

Tupper, M.H., V.C Anthony, S.B. Chenoweth and H.A. MacCluen. 1998. Biology and Assessment of Gulf of Maine herring stocks: A foundation for an innovative industry/science research partnership to ensure a sustainable herring fishery. Gulf of Maine Aquarium. Portland, Maine.

Vabø, R., K. Olsen and I. Huse. 1998. Vessel avoidance of wintering Norwegian spring spawning herring. *J. Acoust. Soc. Am.* 103(5):3035.

Yund, P.O. 2000. Use of Automated Acoustic Data Logging Systems to Survey Atlantic Herring in the Gulf of Maine: 1999-2000 Project Report. Gulf of Maine Aquarium. Portland, Maine.

PARTNERSHIPS

The partnership with the industry on this project was exceptional. Mark Bichrest gave GMRI unlimited access to the F/V Jennifer and Emily as a research platform for the acoustic survey. When GMRI decided to add another week to the survey, the vessel was immediately made available to our request. The two vessel crews employed during the survey were very helpful and accommodating to the scientific staff and provided helpful ancillary information on the distribution of herring observed during commercial fishing trips they conducted when not on acoustic surveys.

IMPACTS / IMPLICATIONS

The outcome from this project is a description of timing, location and biomass levels of Atlantic herring on Jeffreys Ledge during the spawning season. Data indicates that the study area had low levels of spawning fish throughout the entire survey period. Historically, the Jeffreys Ledge region has shown to be an area of importance to spawning for Atlantic herring. It would appear that this was not the case in 2006 and that a possible shift in the major spawning location for the Gulf of Maine has occurred.

The results from this survey should be of great interest to both the industry and scientists. It would seem that the industry was already aware of the lack of fish on Jeffreys Ledge as most of the fishing during the study period took place off the midcoast and eastern portions of Maine. For scientists, this information should be significant for understanding the inshore spawning component of Atlantic herring. If there was a shift in the major spawning location, the need for why it happened is important. Is a result of fishing pressure, environmental parameters or a natural occurrence?

This report should be forwarded to:

William Overholtz
Research Fish Biologist
National Marine Fisheries Service
166 Water Street, Woods Hole, MA 02543
william.overholtz@noaa.gov

Michael Jech
Research Fish Biologist
National Marine Fisheries Service
166 Water Street, Woods Hole, MA 02543
michael.jech@noaa.gov

Lori Steele
Fishery Analyst
New England Fishery Management Council
50 Water Street, Mill 2
Newburyport, MA 01950
lsteel@nefmc.org

PRESENTATIONS

Poster:

Daniel J. Salerno

Inshore Gulf of Maine Acoustic Survey of Atlantic Herring Sentinel Spawning Grounds

Maine Fishermen's Forum

March 1 – 3, 2007

Rockland, Maine

PowerPoint presentation:

Shale Rosen

GMRI Herring Working Group Meeting

May 17, 2007

FUTURE RESEARCH

1. This project demonstrated that a “sentinel” survey approach to assessing Atlantic herring in the Gulf of Maine is feasible. It is critical that “sentinel” surveys such as this be conducted on an ongoing basis in order to detect changes over time. The survey should also be expanded to cover other areas of known importance to Atlantic herring as spawning sites.
2. Future work related to acoustic surveys of Atlantic herring should be broadened to encompass greater coverage in the Gulf of Maine. Spawning by the Gulf of Maine stock component ranges from downeast Maine to Stellwagen Bank. A survey encompassing the entire area would be useful in determining more precise biomass estimates related to the inshore portion of the entire stock complex.

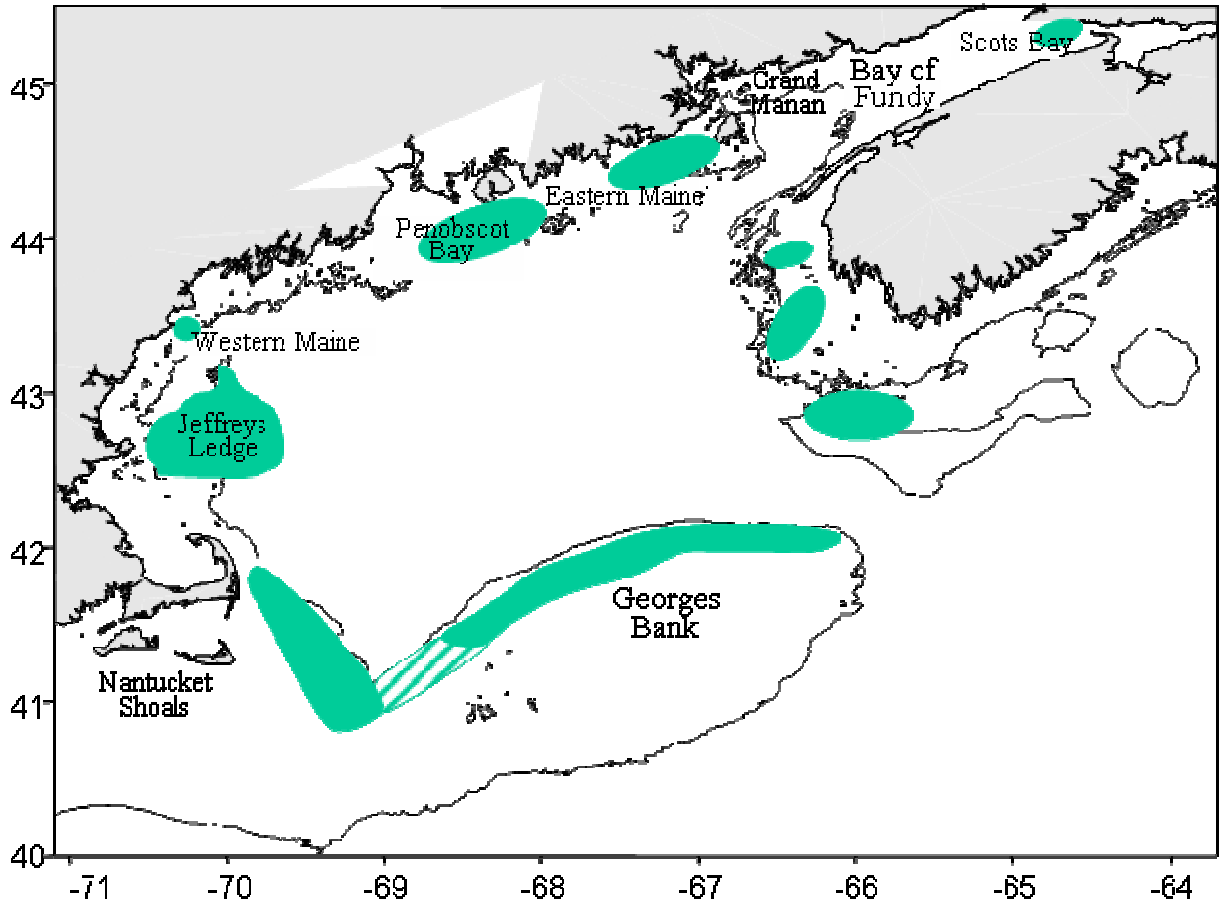

Figure 1. Atlantic herring spawning sites within the Gulf of Maine and Bay of Fundy.

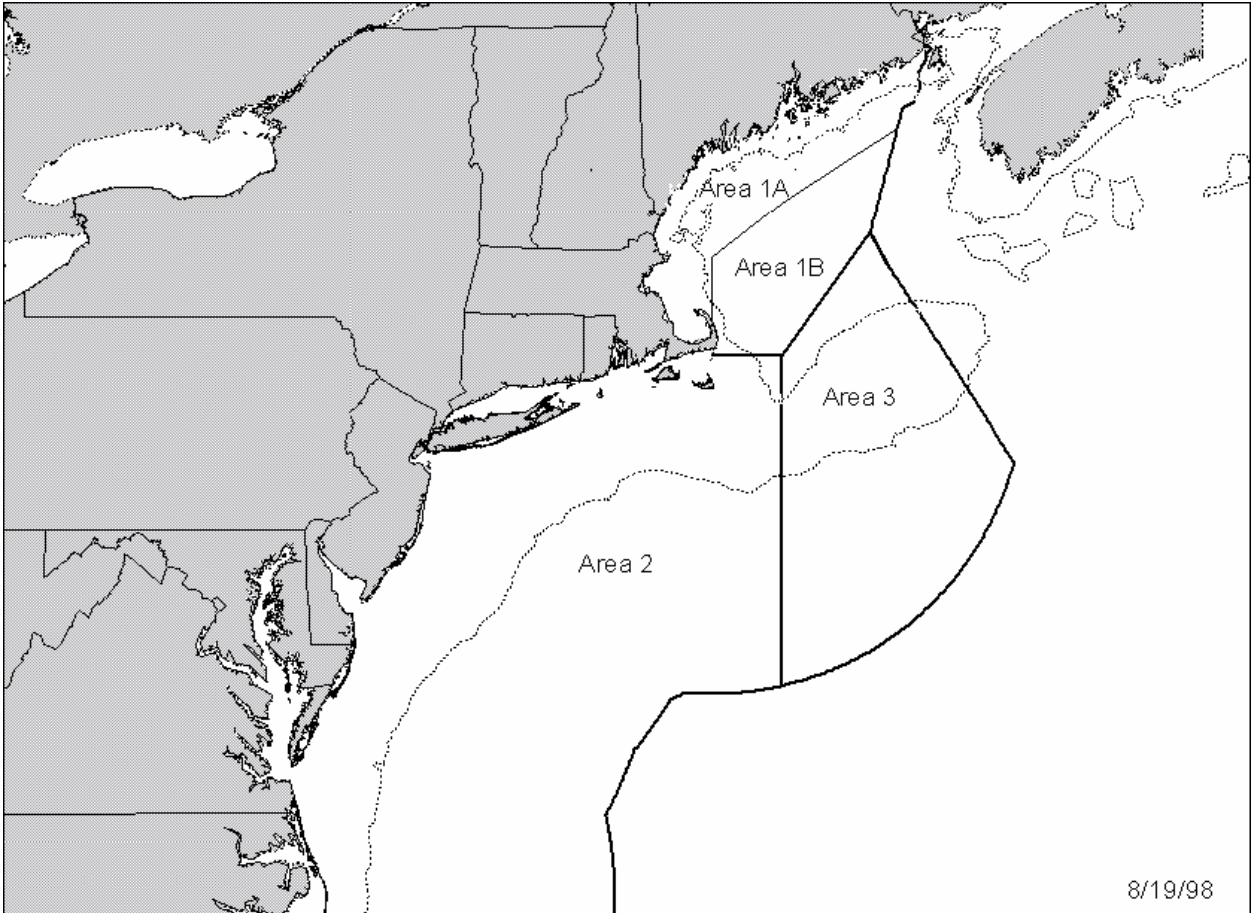

Figure 2. U.S. Atlantic herring fishery management areas.

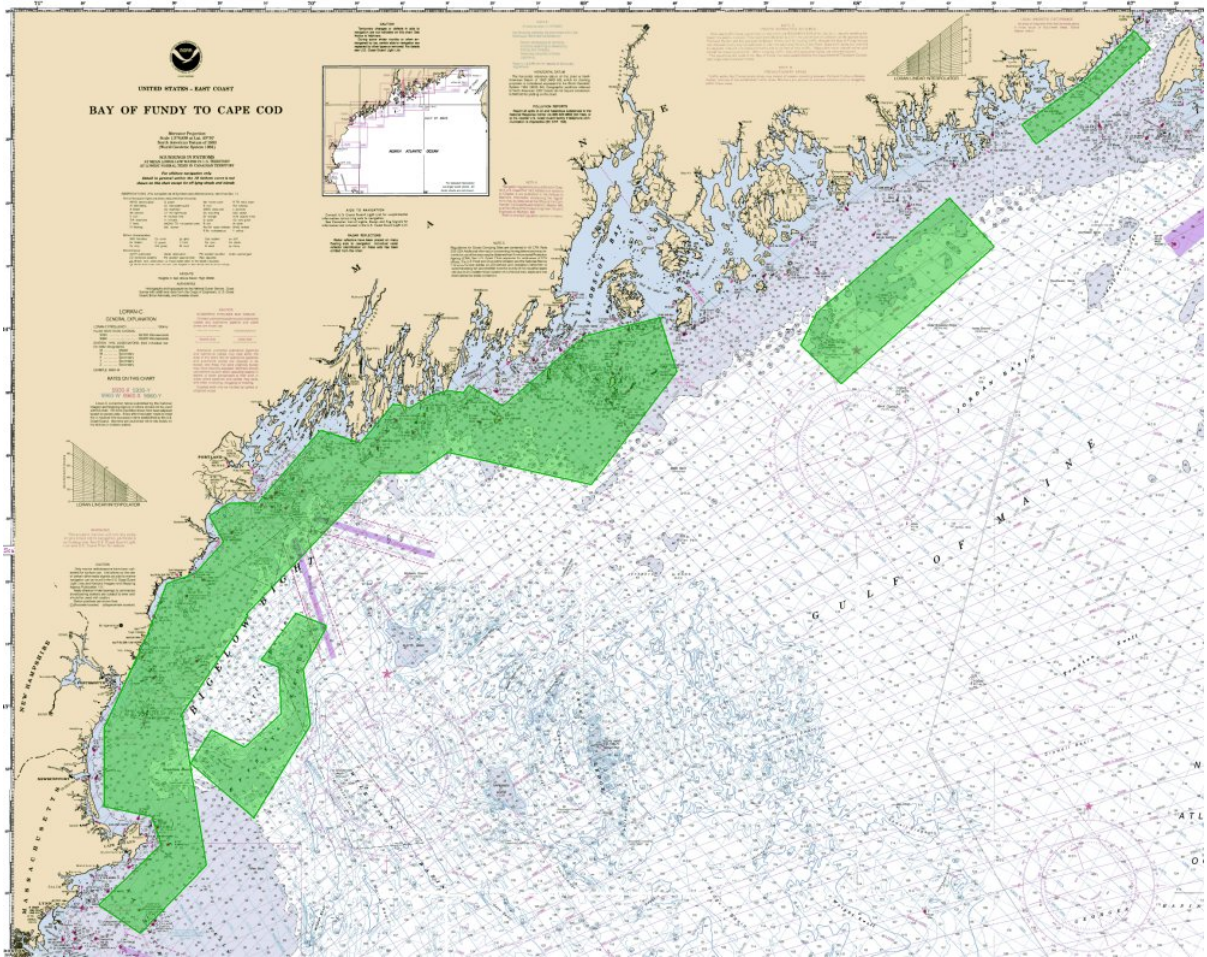

Figure 3. Generalized coverage of past GMRI acoustic surveys for Atlantic herring in the Gulf of Maine.

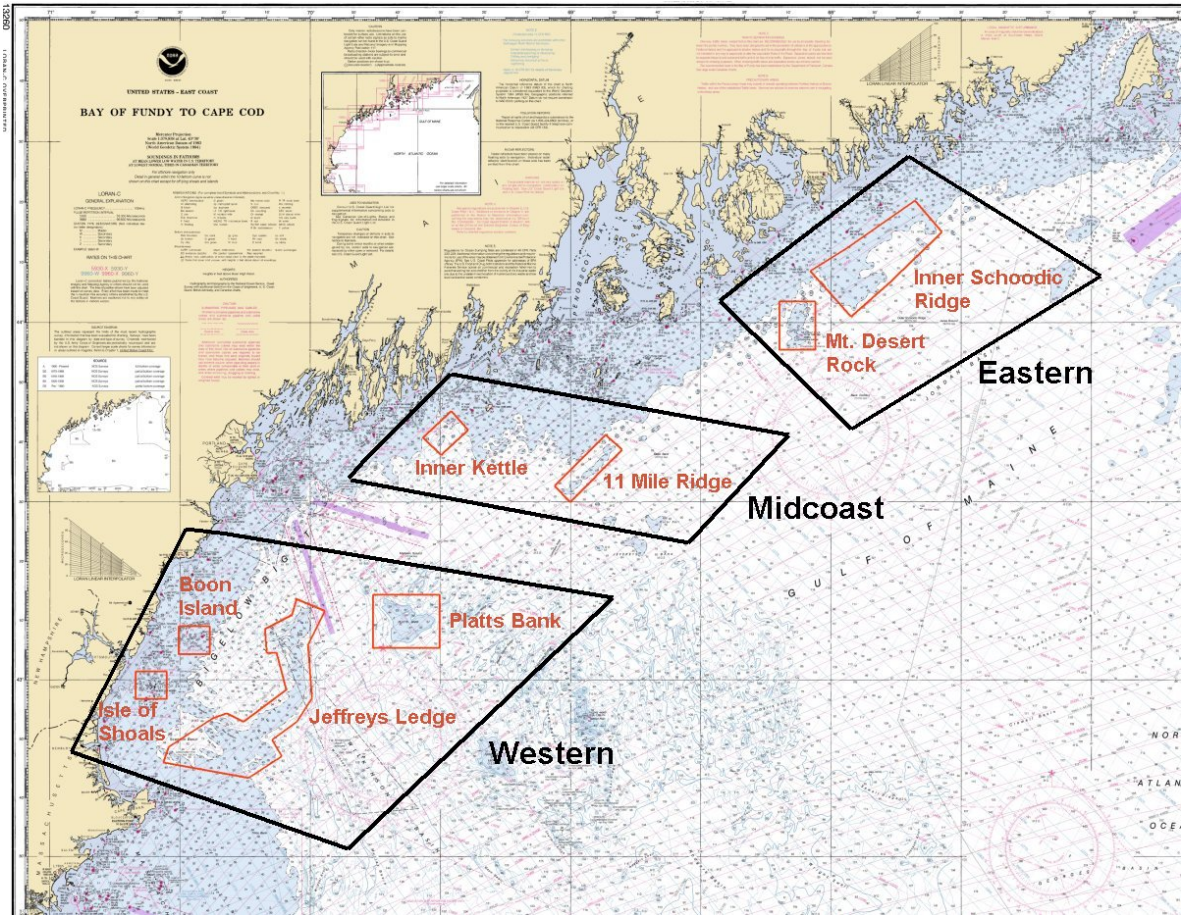

Figure 4. Study area for 2006 acoustic survey of Atlantic herring.

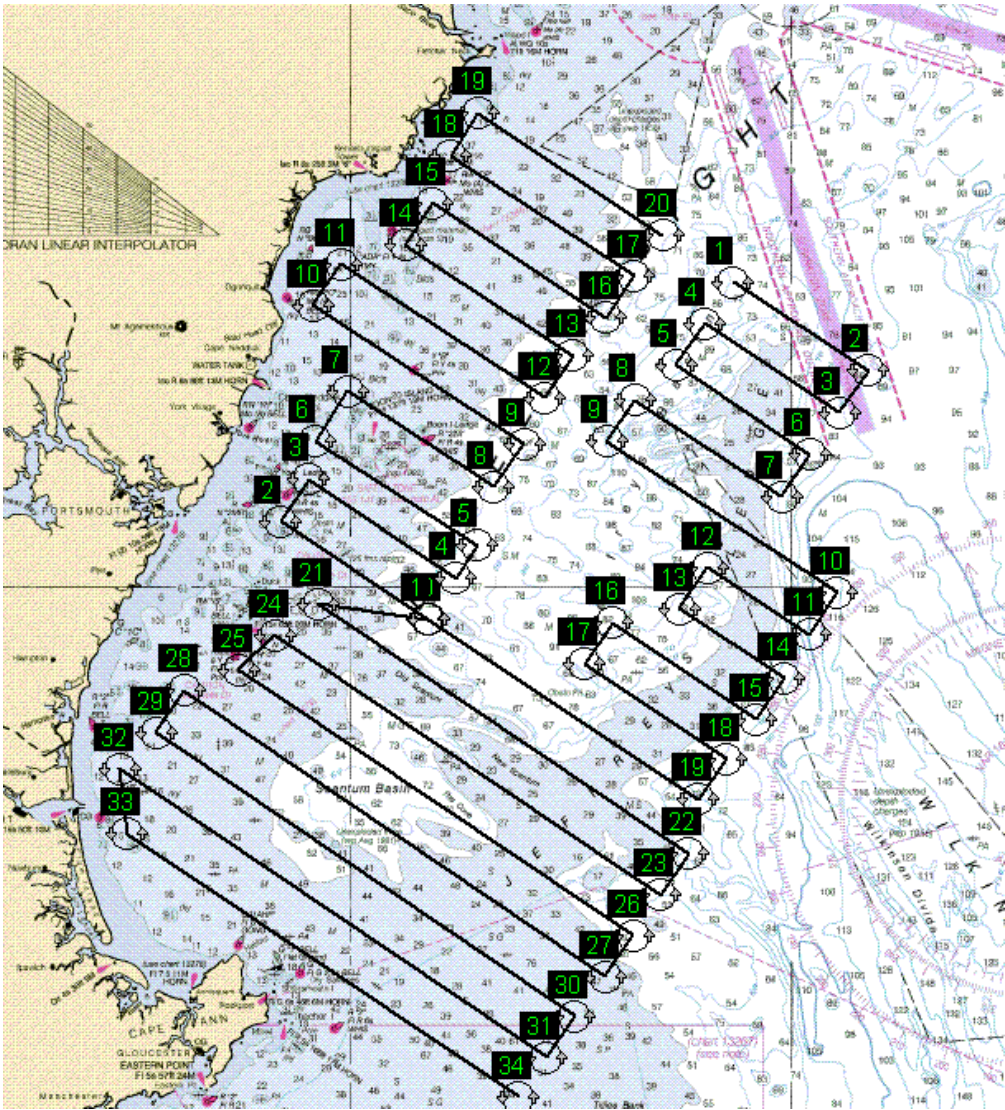

Figure 5. Vessel trackline utilized in the acoustic survey.



Figure 6. F/V Jennifer & Emily.

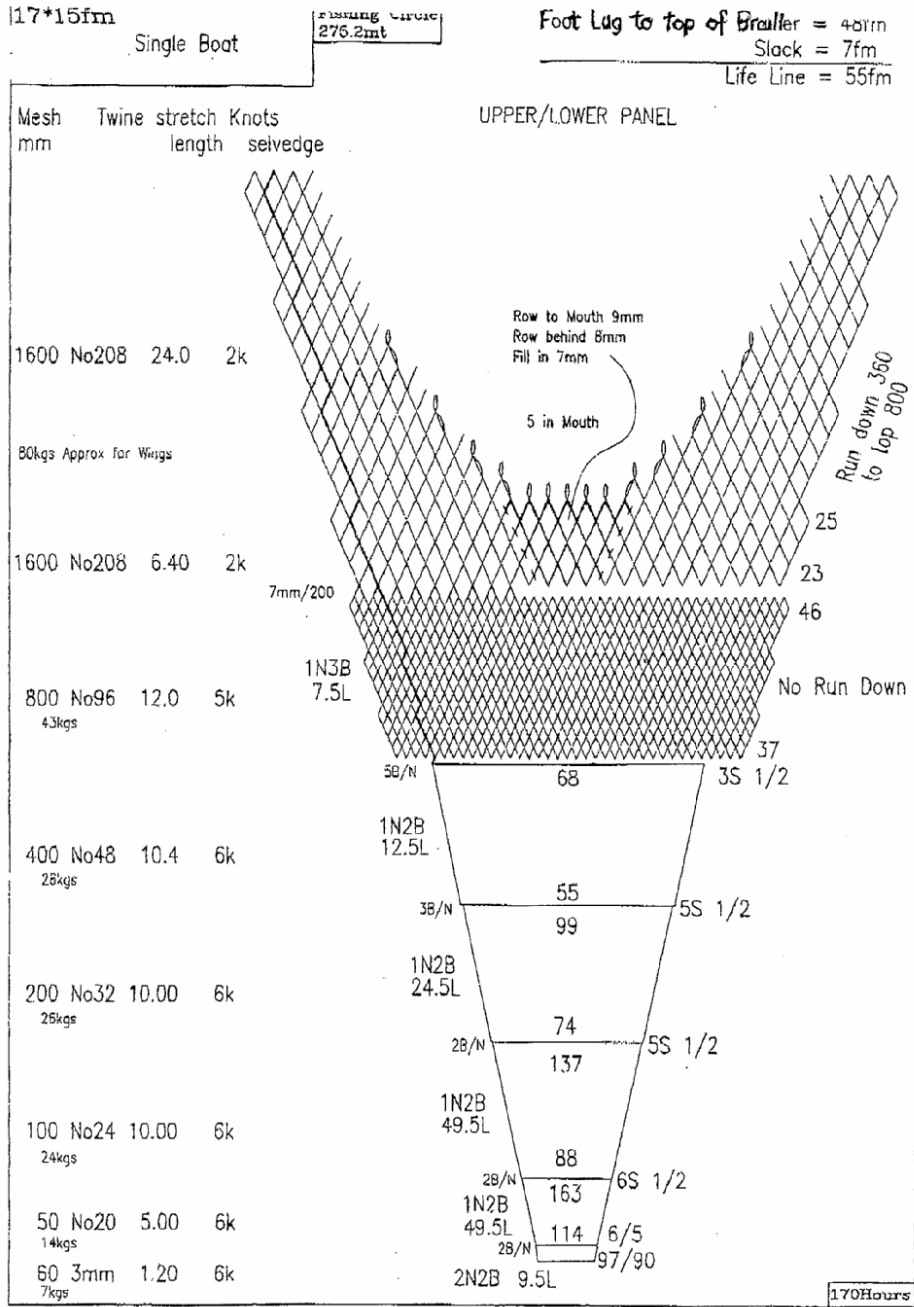

Figure 7a. Net diagram of midwater trawl used in acoustic survey, upper and lower panel.

11713

Single Boat

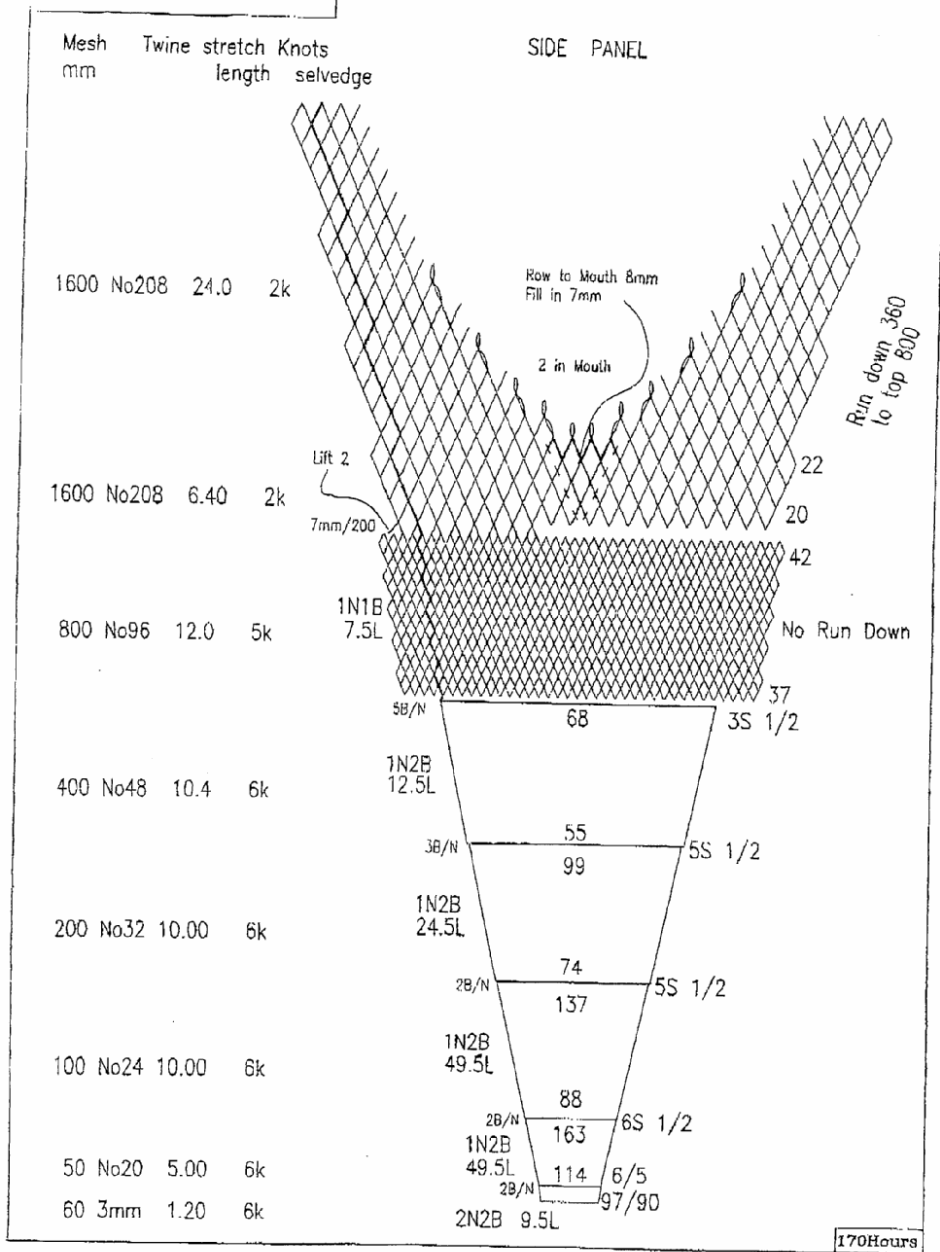

Figure 7b. Net diagram of midwater trawl used in acoustic survey, side panel.

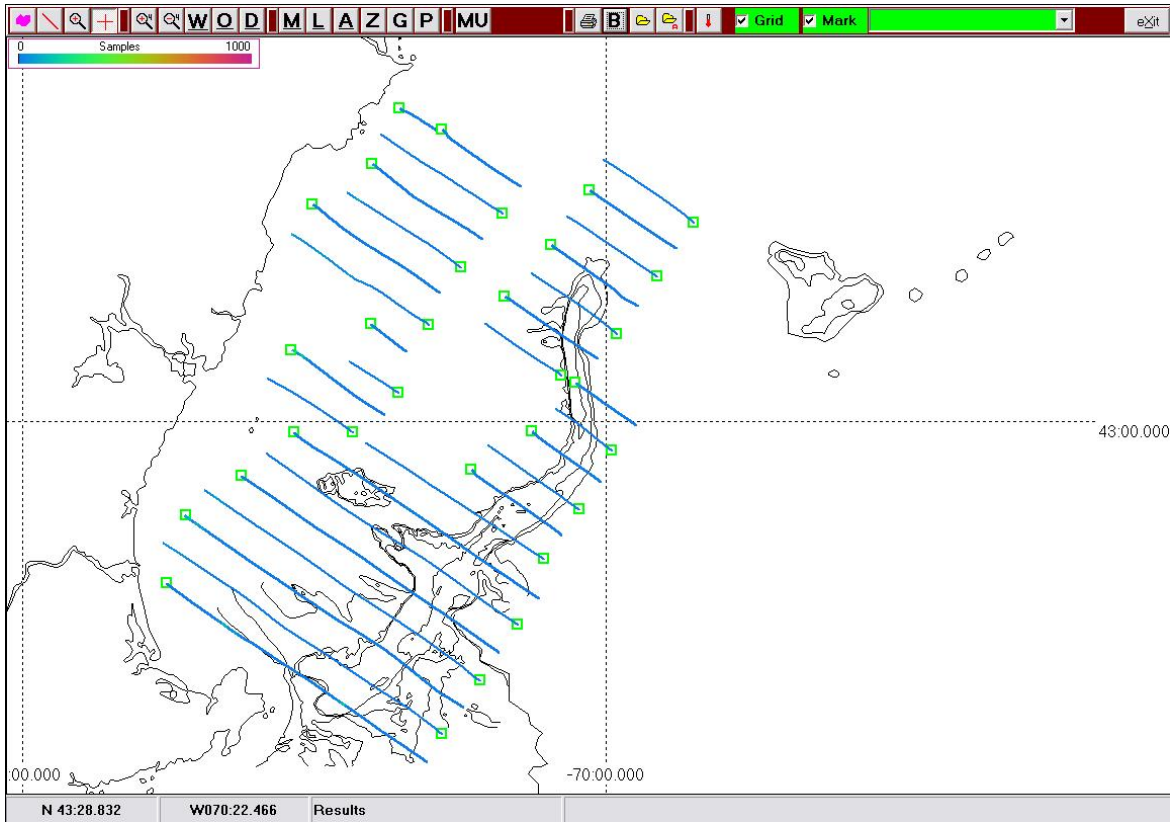

Figure 8. Survey transect coverage for Leg 1, August 21 – 26. (Note that no samples tows were made during Leg 1.)

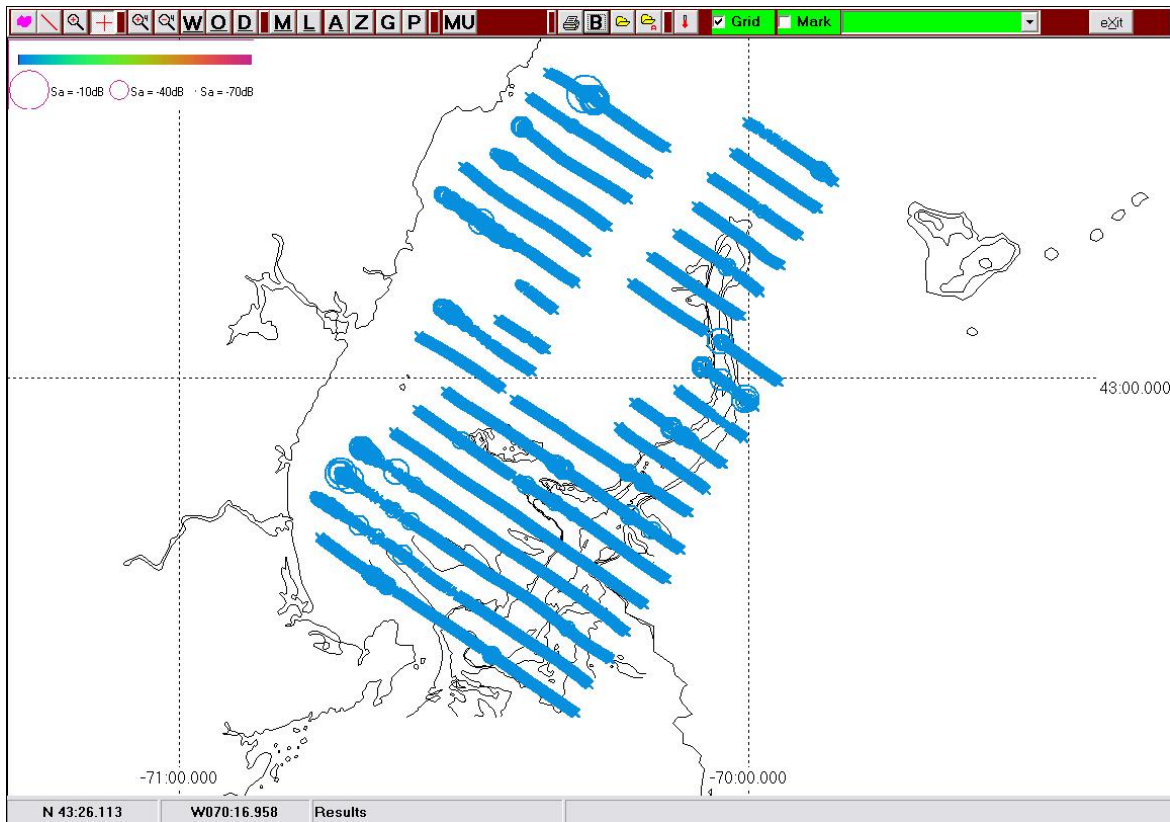

Figure 9. Total Atlantic herring distribution for Leg 1, August 21 – 26. (Note that no samples tows were made during Leg 1.)

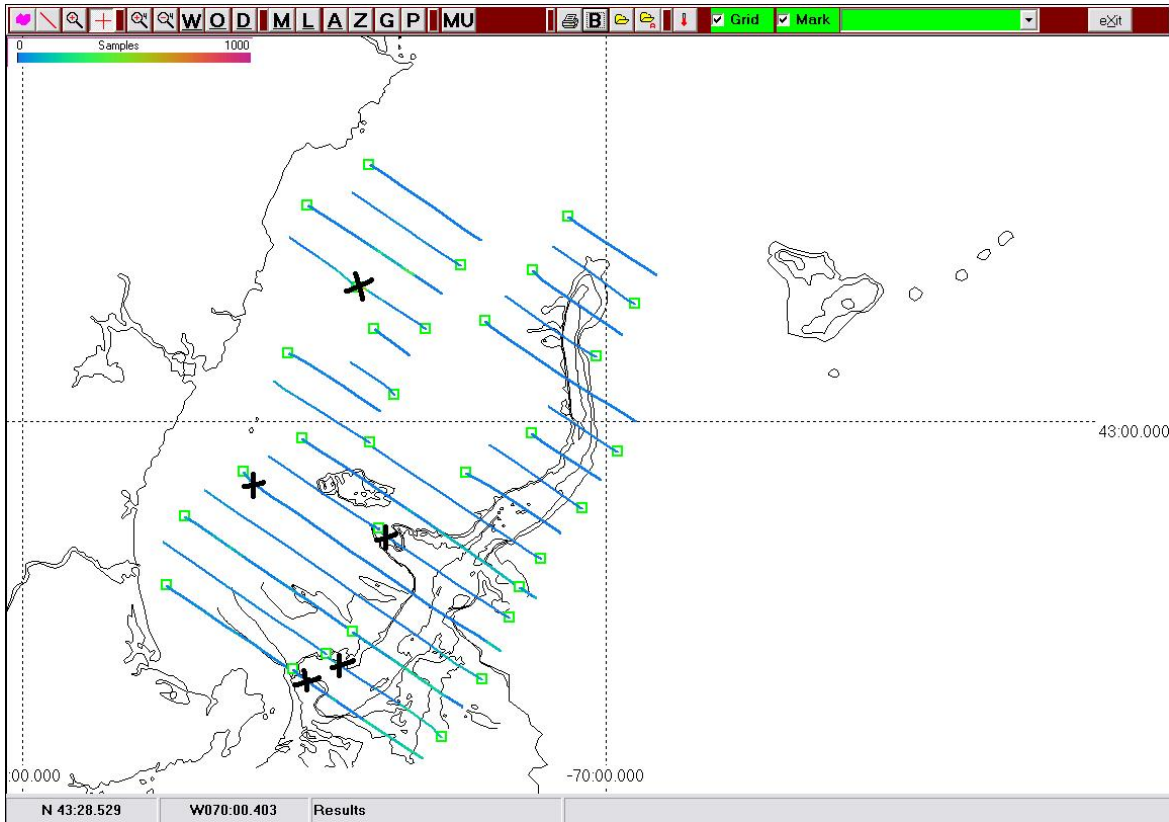

Figure 10. Survey transect coverage for Leg 2, September 5 – 10. The black X marks the location of successful sample tows.

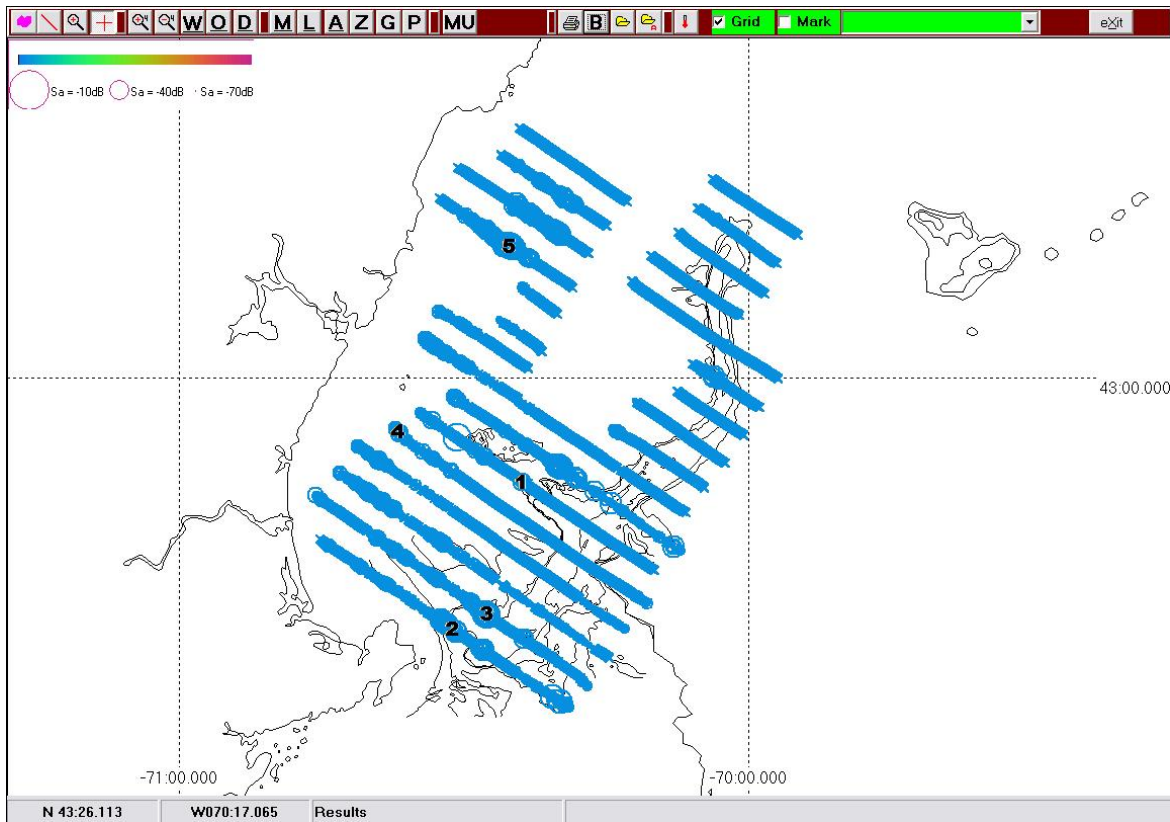

Figure 11. Total Atlantic herring distribution for Leg 2, September 5 – 10. Numbers denote location and order of sample tows.

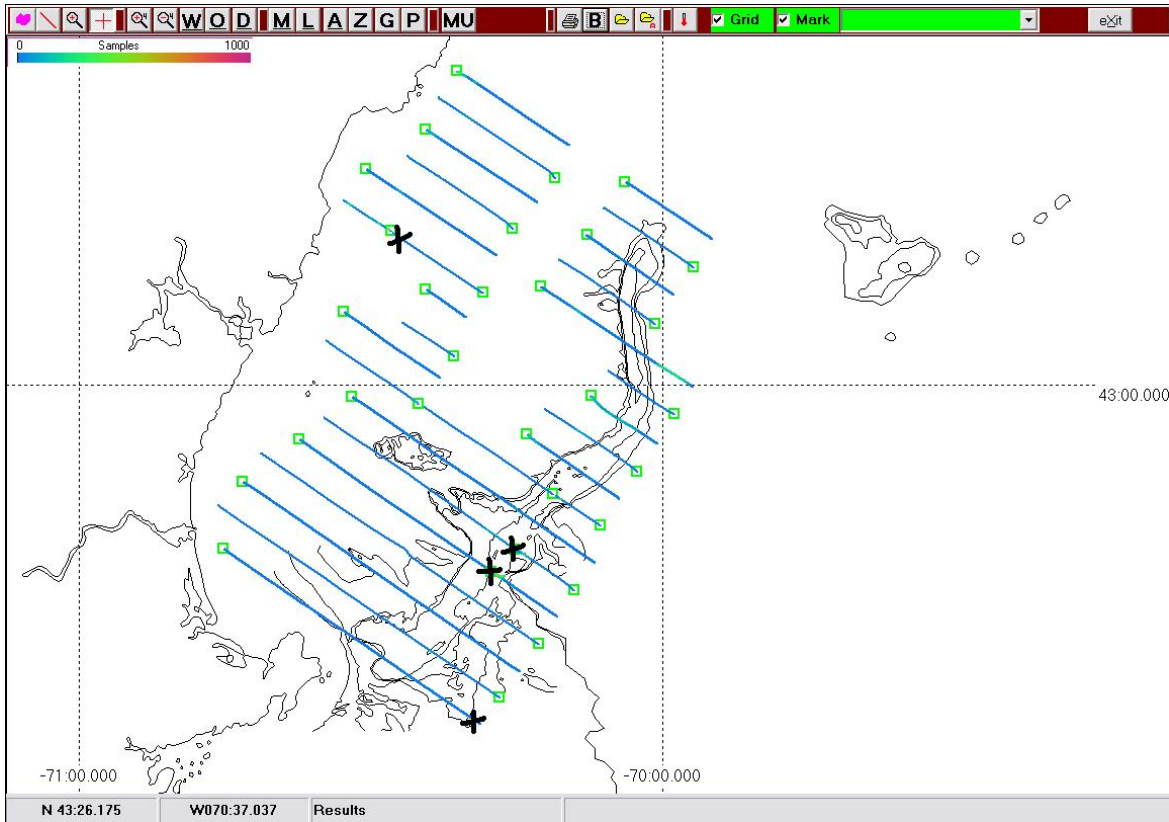

Figure 12. Survey transect coverage for Leg 3, September 18 – 23. The black X marks the location of successful sample tows.

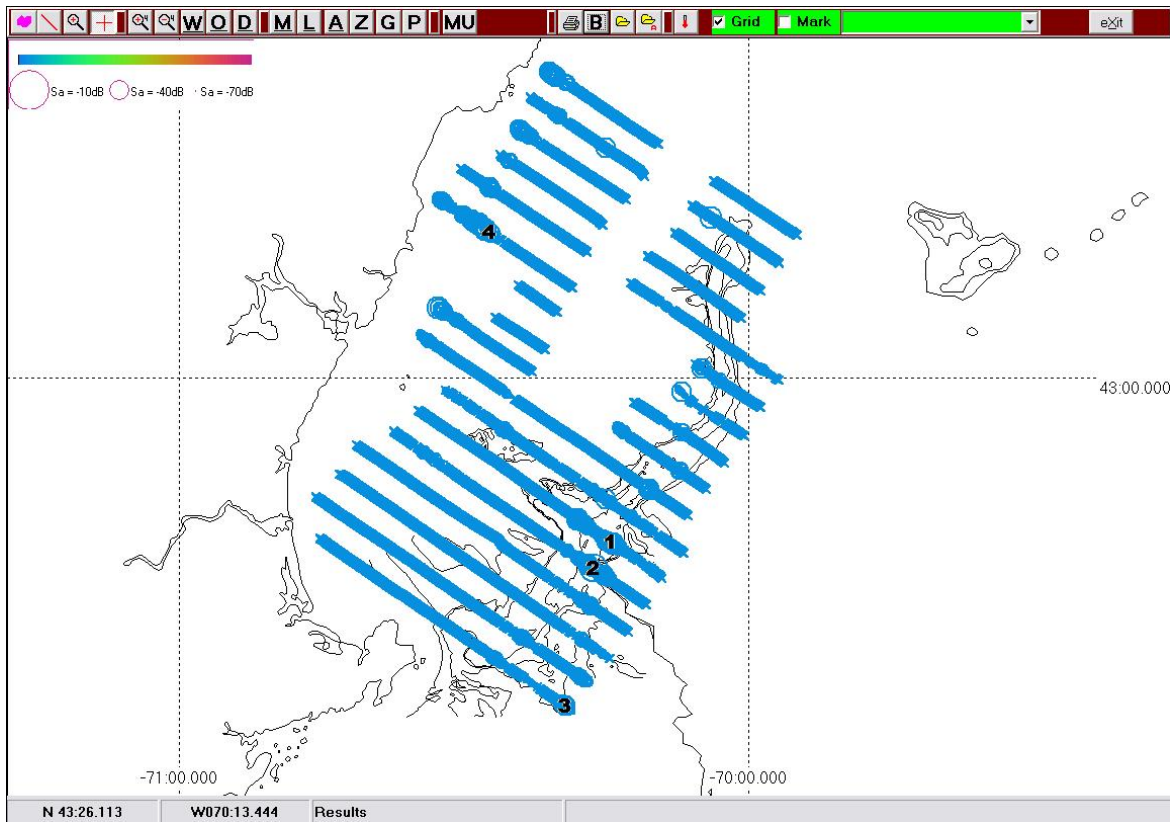

Figure 13. Total Atlantic herring distribution for Leg 3, September 18 – 23. Numbers denote location and order of sample tows.

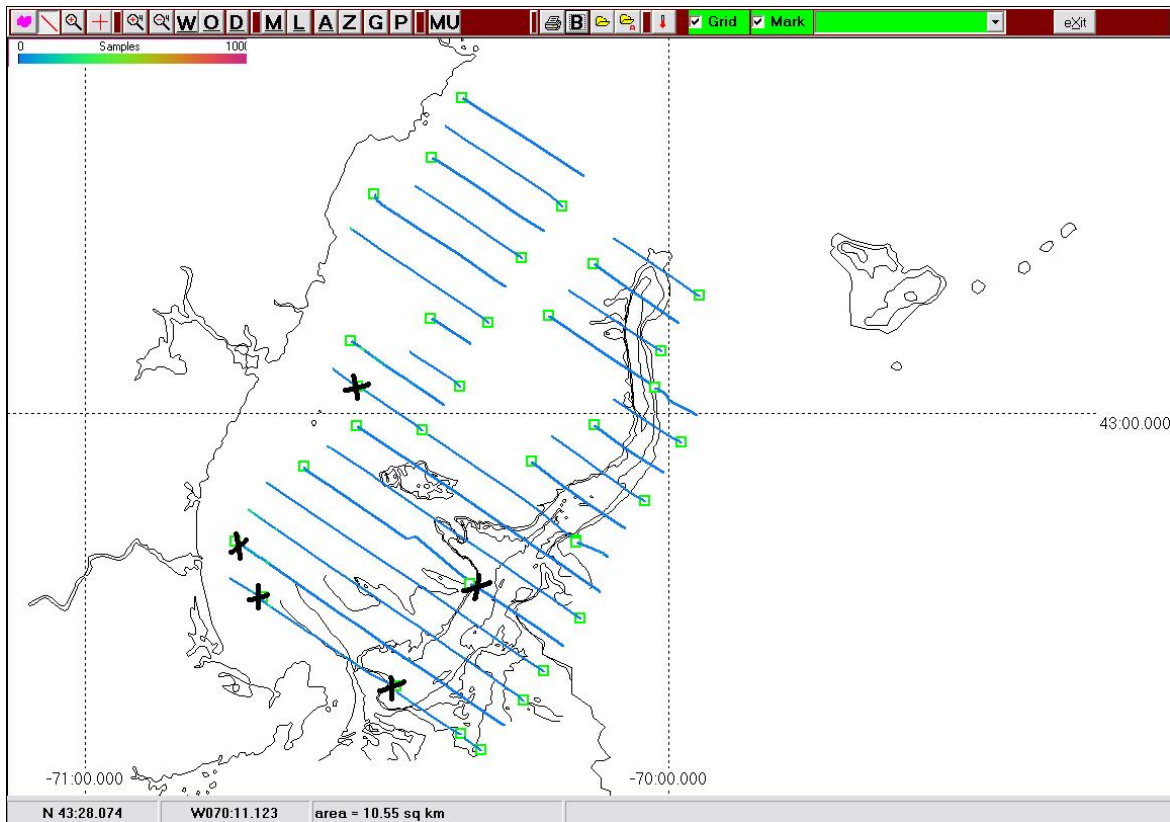

Figure 14. Survey transect coverage for Leg 4, October 2 – 7. The black X marks the location of successful sample tows.

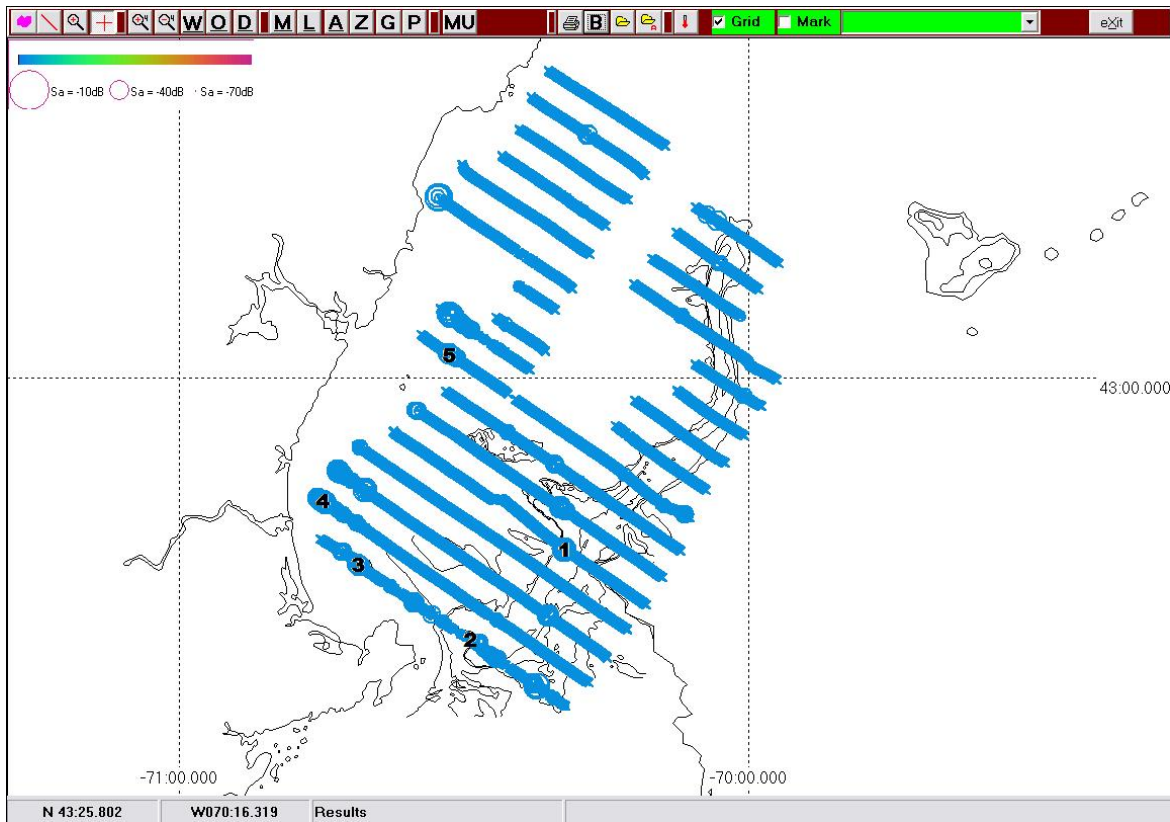

Figure 15. Total Atlantic herring distribution for Leg 4, October 2 – 7. Numbers denote location and order of sample tows.

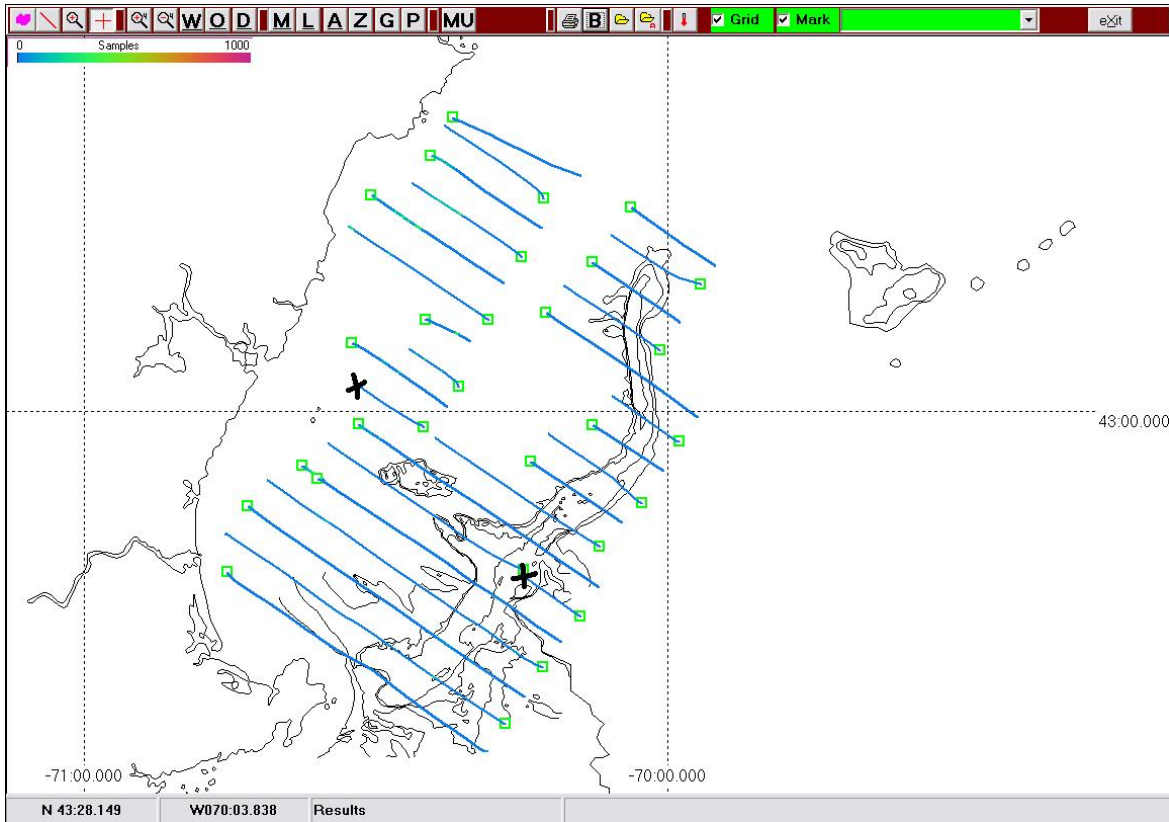

Figure 16. Survey transect coverage for Leg 5, October 16 – 20. The black X marks the location of successful sample tows.

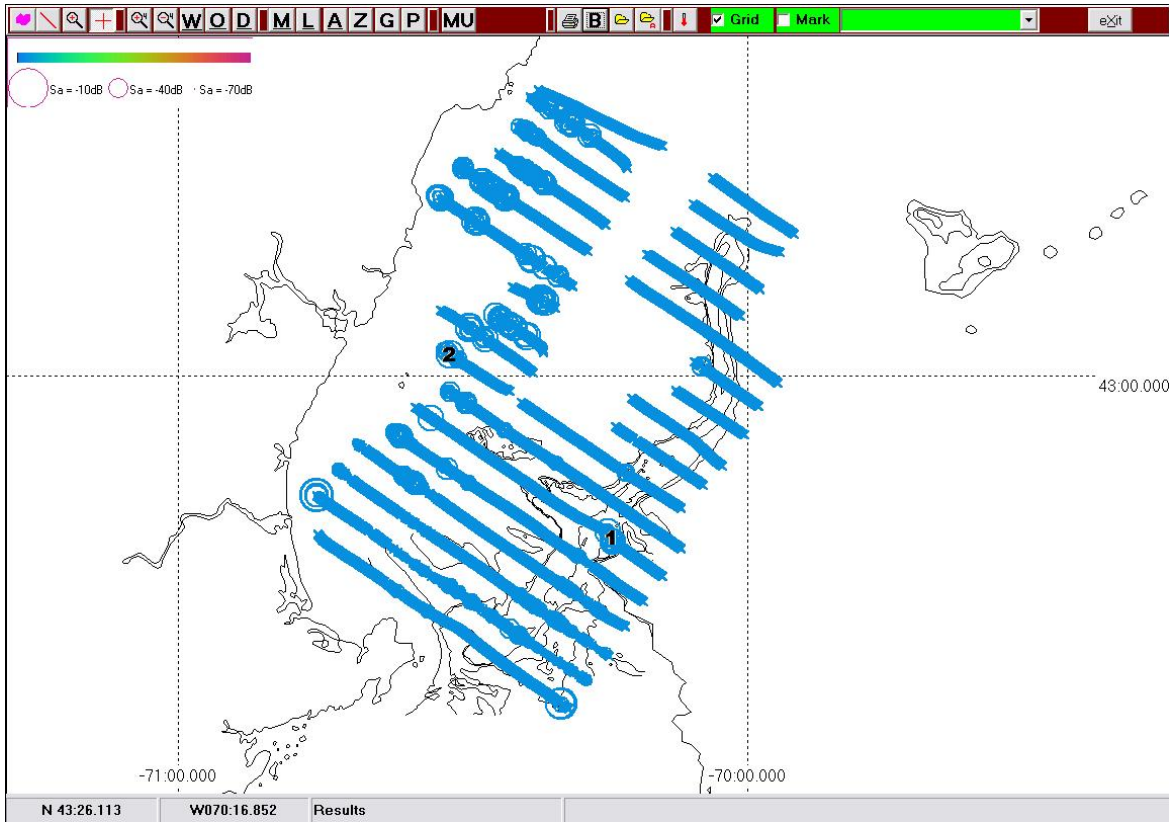

Figure 17. Total Atlantic herring distribution for Leg 5, October 16 – 20. Numbers denote location and order of sample tows.

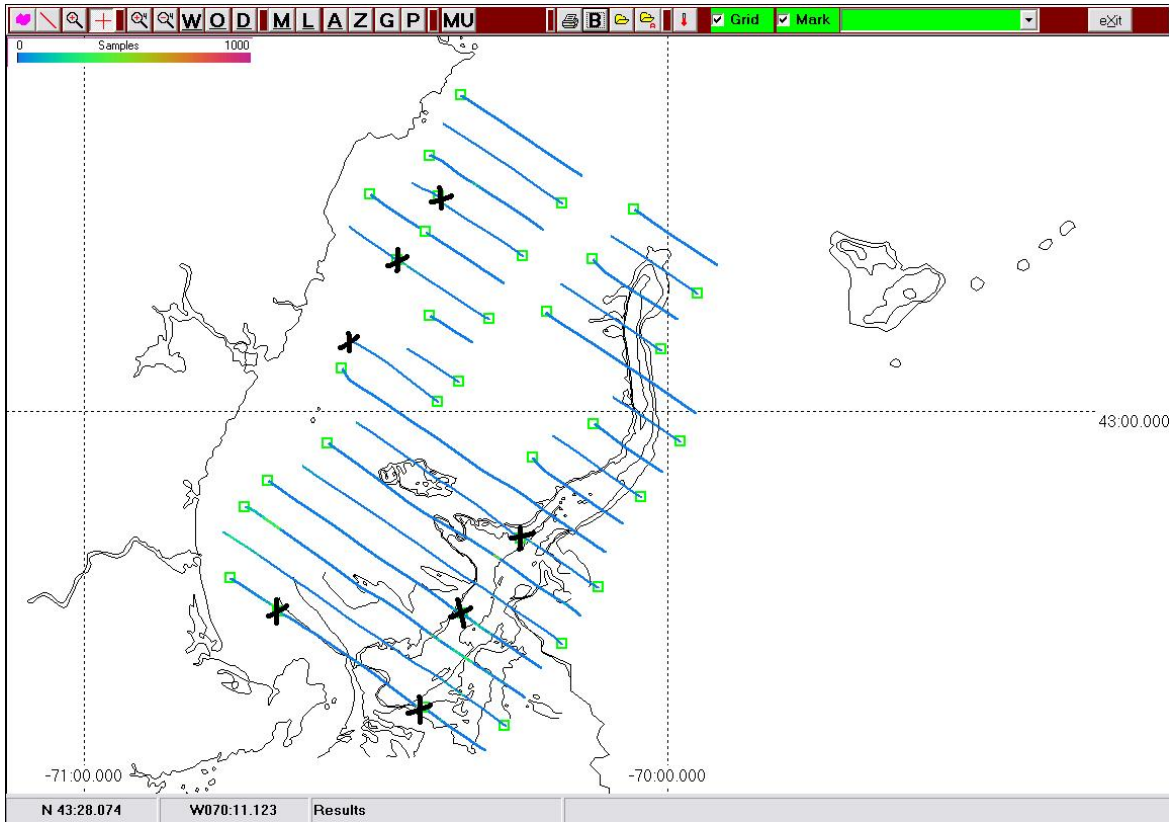

Figure 18. Survey transect coverage for Leg 6, October 23 – 28. The black X marks the location of successful sample tows.

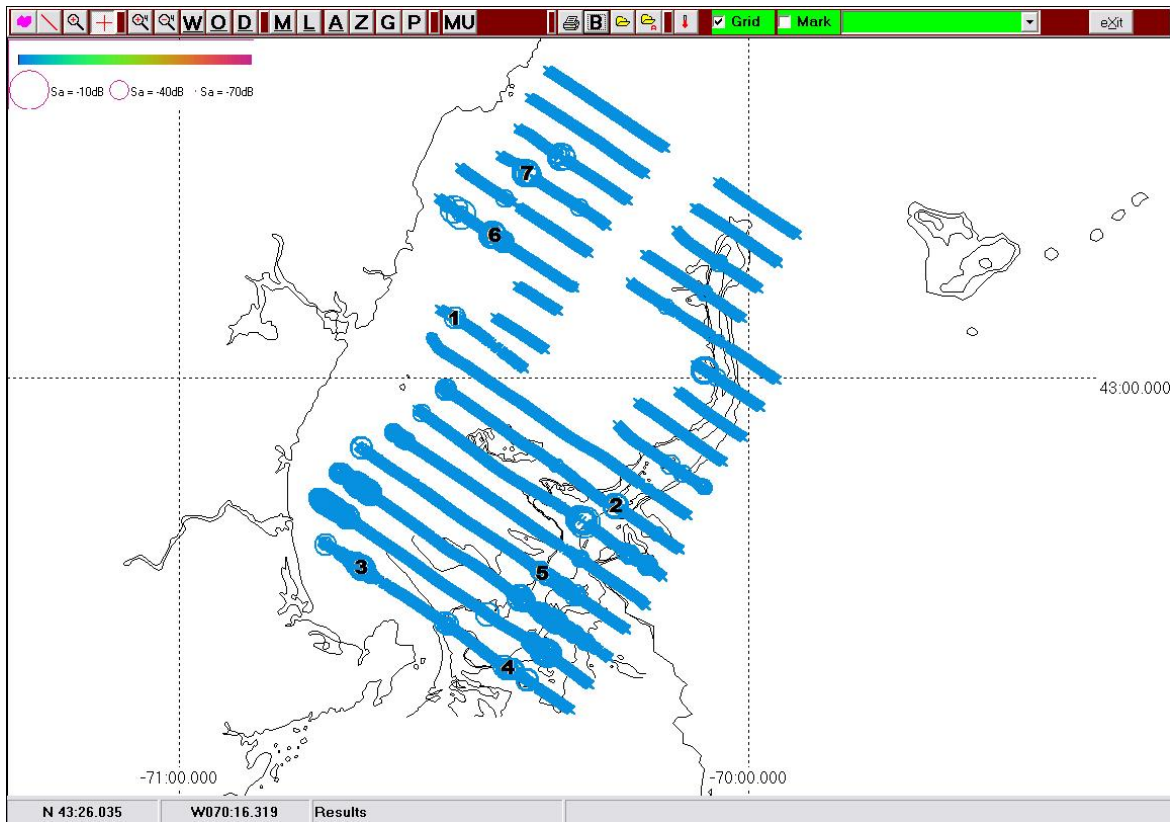

Figure 19. Total Atlantic herring distribution for Leg 6, October 23 – 28. Numbers denote location and order of sample tows.

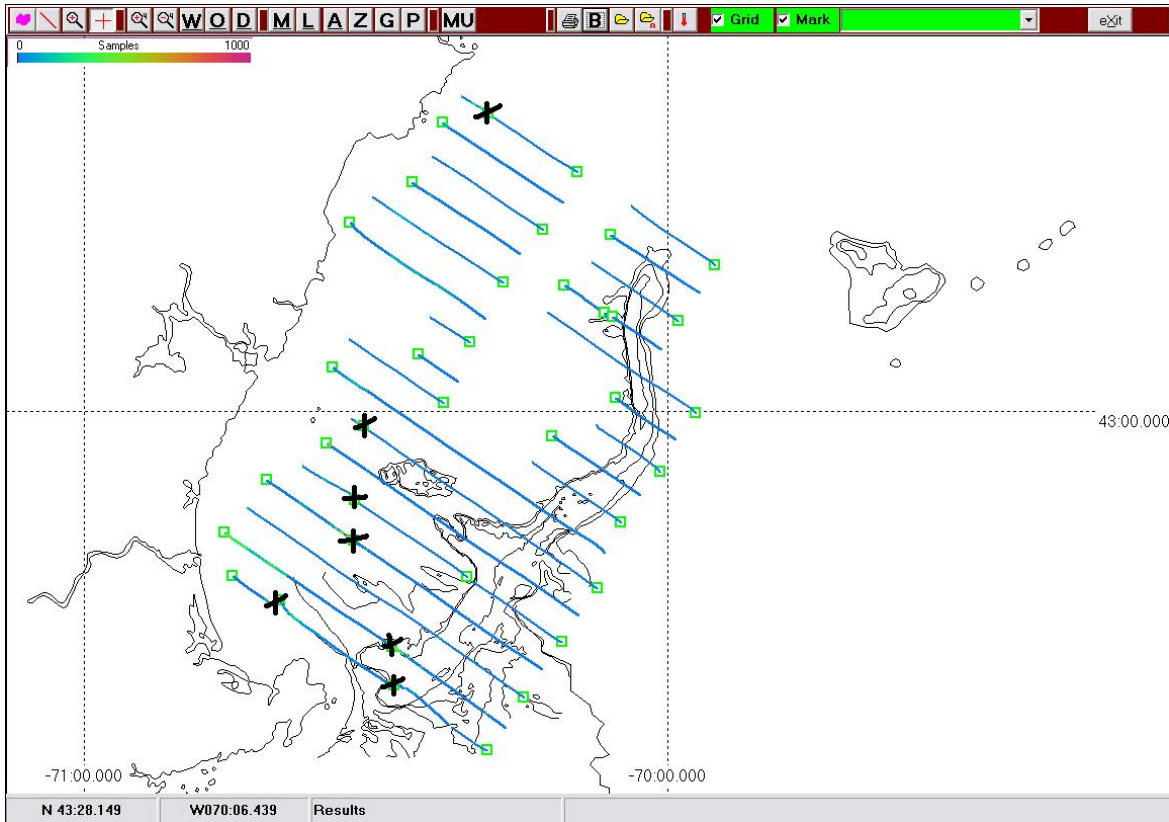

Figure 20. Survey transect coverage for Leg 7, October 30 – November 3. The black X marks the location of successful sample tows.

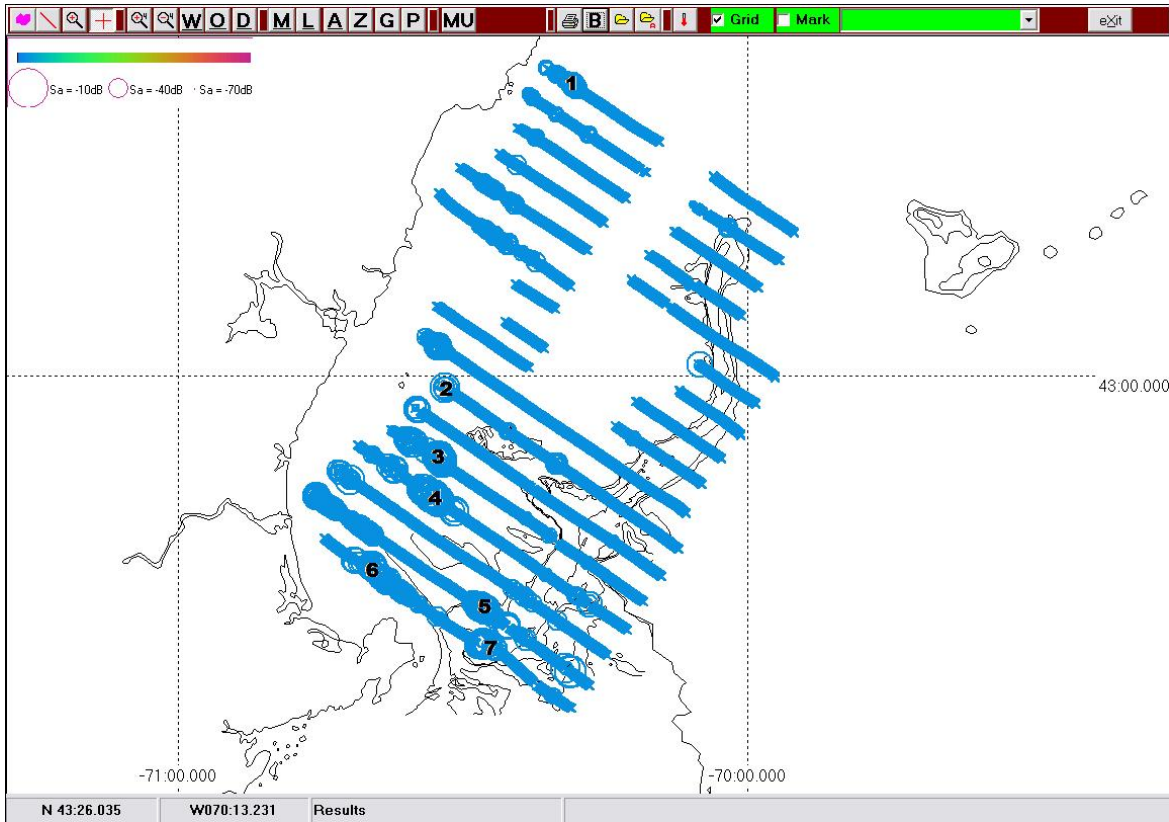

Figure 21. Total Atlantic herring distribution for Leg 7, October 30 – November 3. Numbers denote location and order of sample tows.

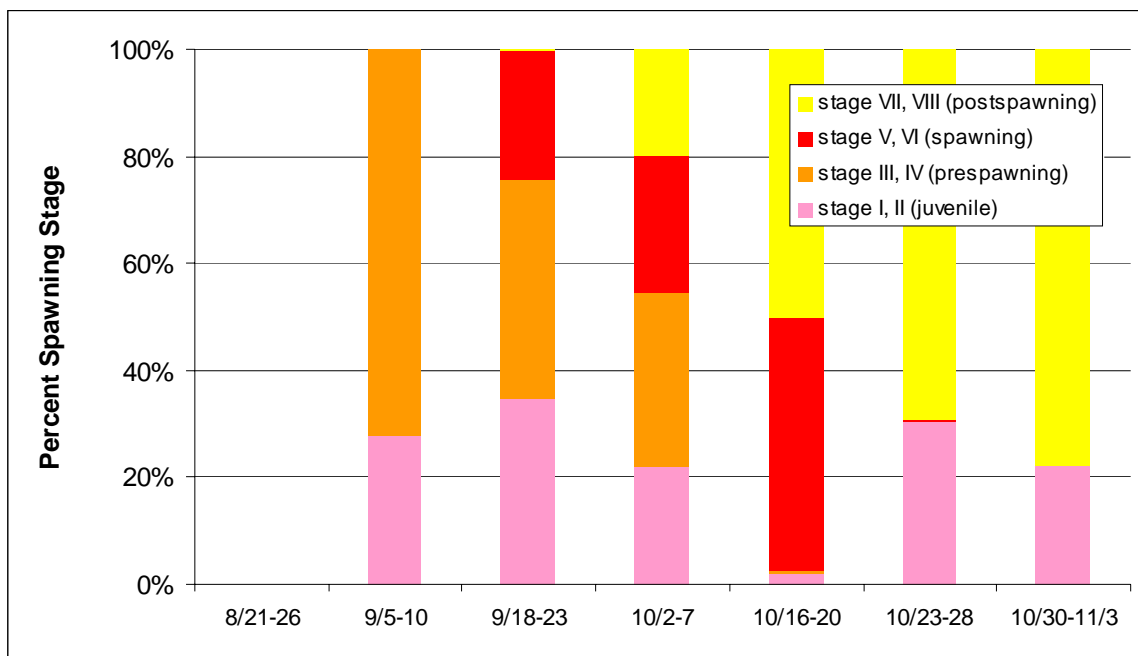
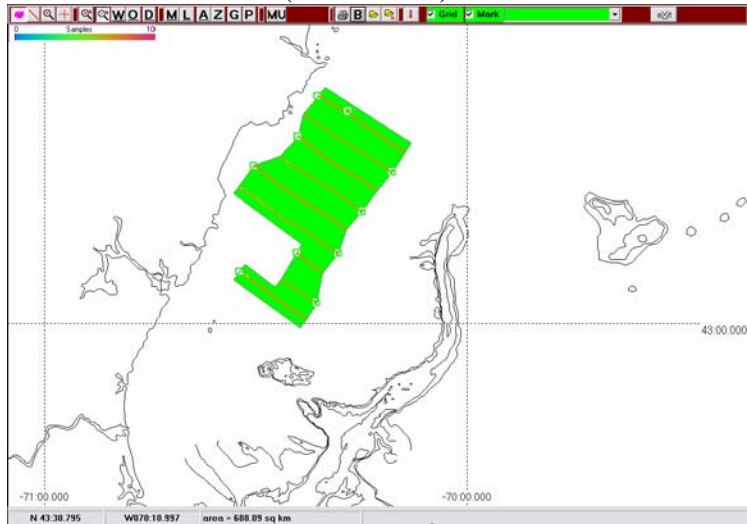
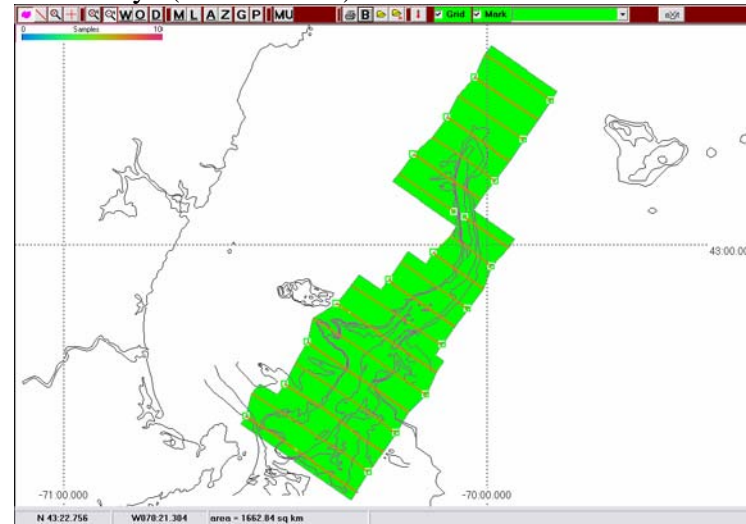

Figure 22. Percent spawning stage for Atlantic herring by leg. (Note that no samples were collected in Leg 1.)

A. Northern Inshore (688.09 km²)



B. Jeffreys (1662.84 km²)



C. Southern Inshore (743.66 km²)

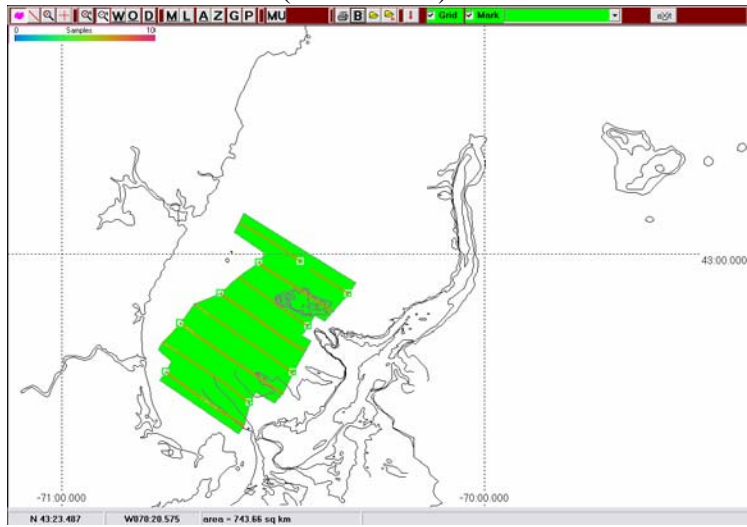
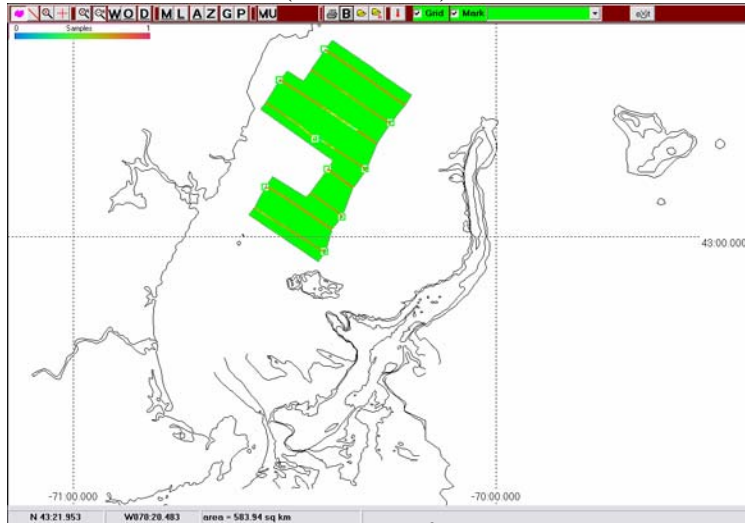
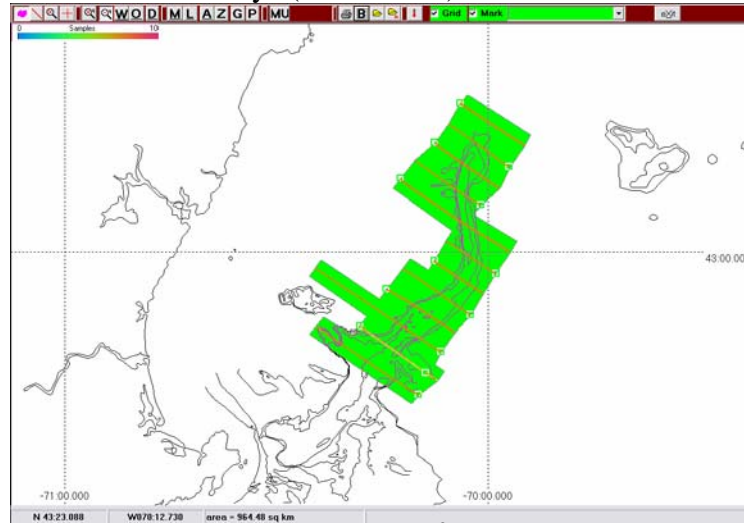

Figure 23. Sub areas used for total biomass estimate of Leg 1 (August 21 – 26).

A. Northern Inshore (583.94 km²)



B. Northern Jeffreys (964.48 km²)



C. Southern Inshore (739.69 km²)

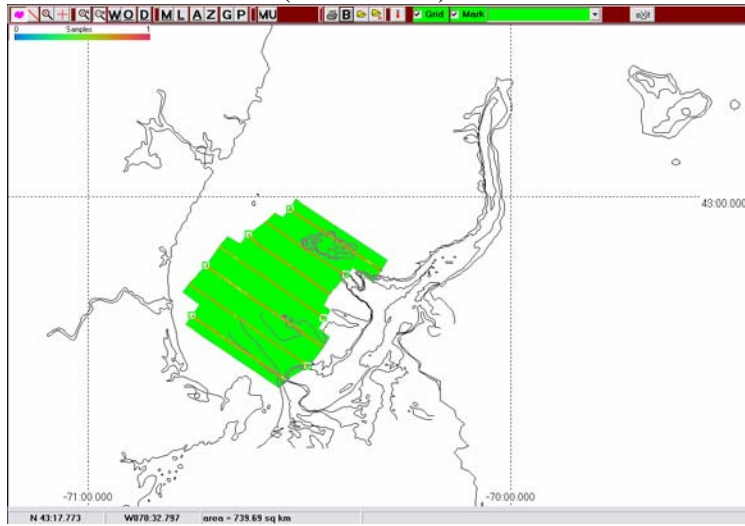

D. Southern Jeffreys (478.54 km²)

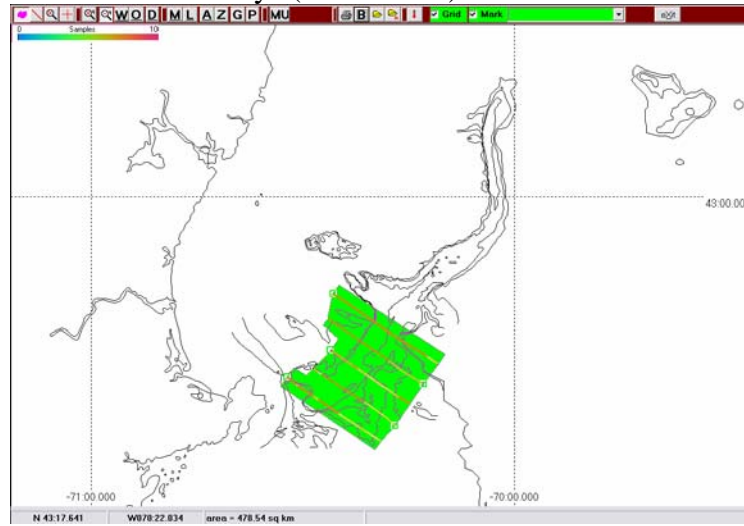
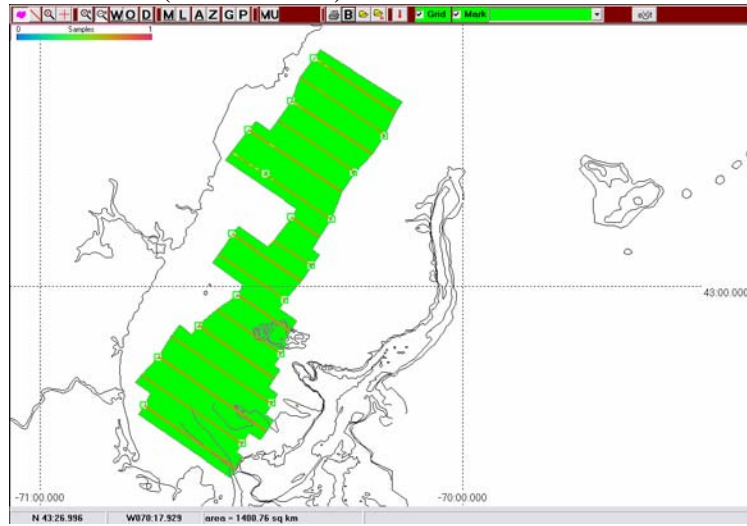
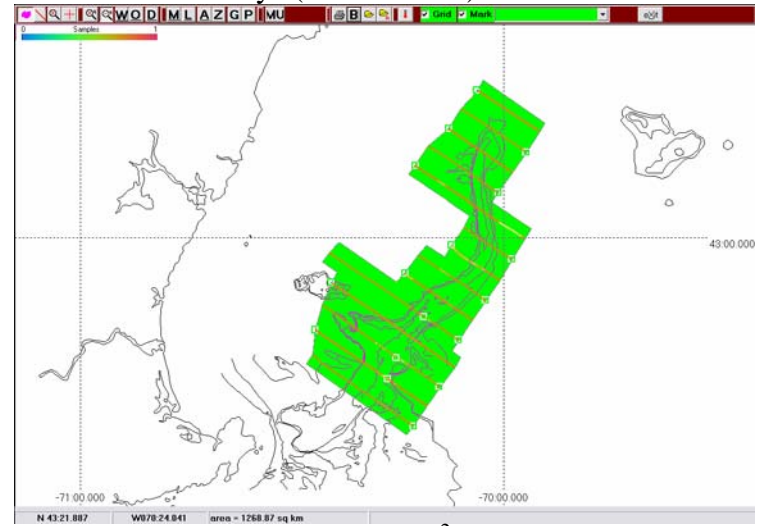

Figure 24. Sub areas used for total biomass estimate of Leg 2 (September 5 – 10).

A. Inshore (1400.76 km²)



B. Northern Jeffreys (1268.87 km²)



C. Southern Jeffreys (300.76 km²)

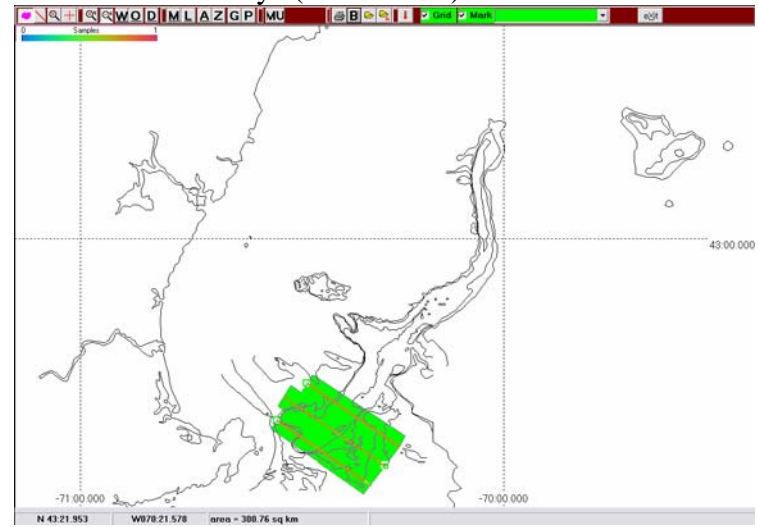
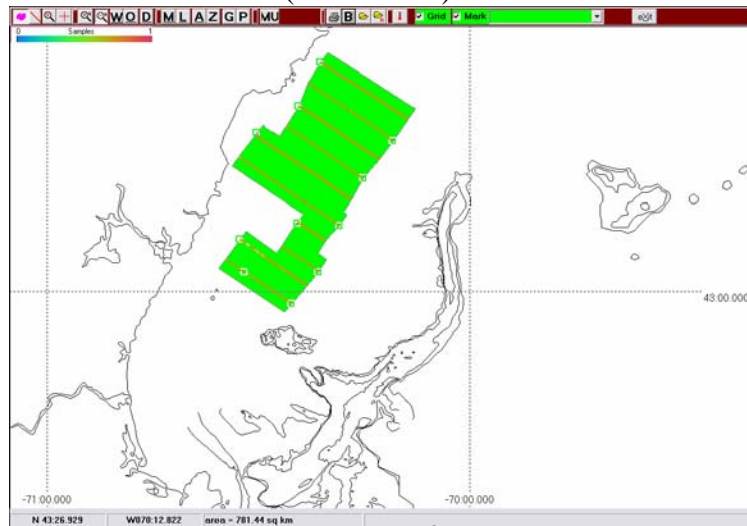
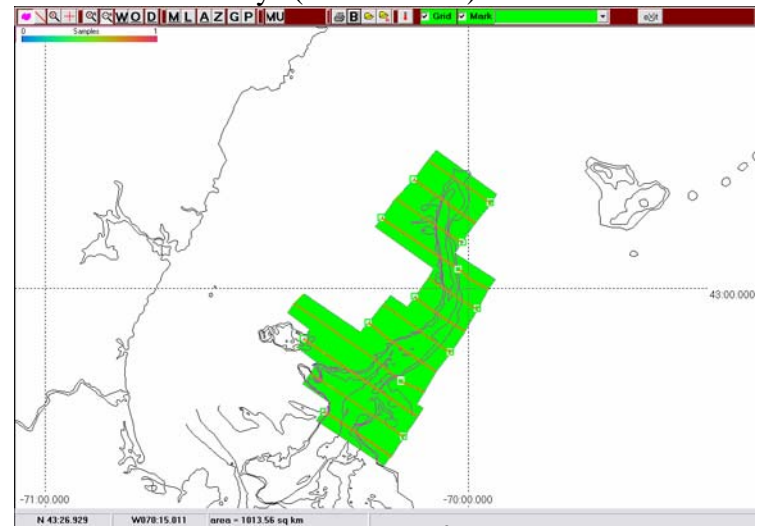

Figure 25. Sub areas used for total biomass estimate of Leg 3 (September 18 – 23).

A. Northern Inshore (781.44 km²)



B. Northern Jeffreys (1013.56 km²)



C. Southern Inshore (793.13 km²)

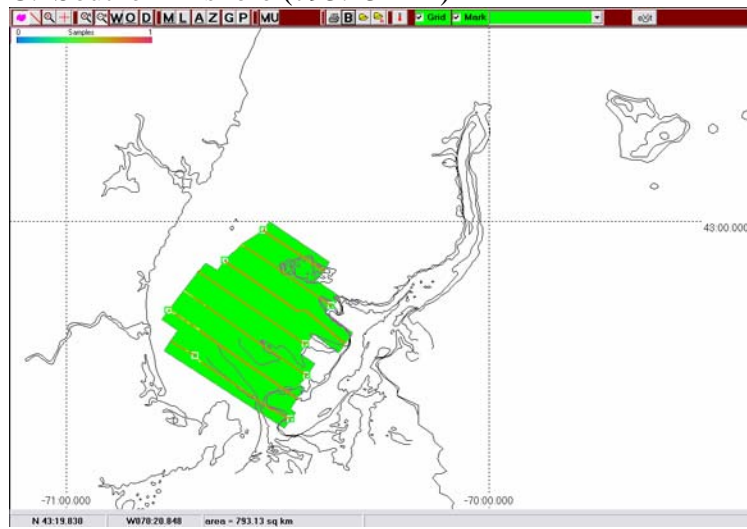

D. Southern Jeffreys (328.08 km²)

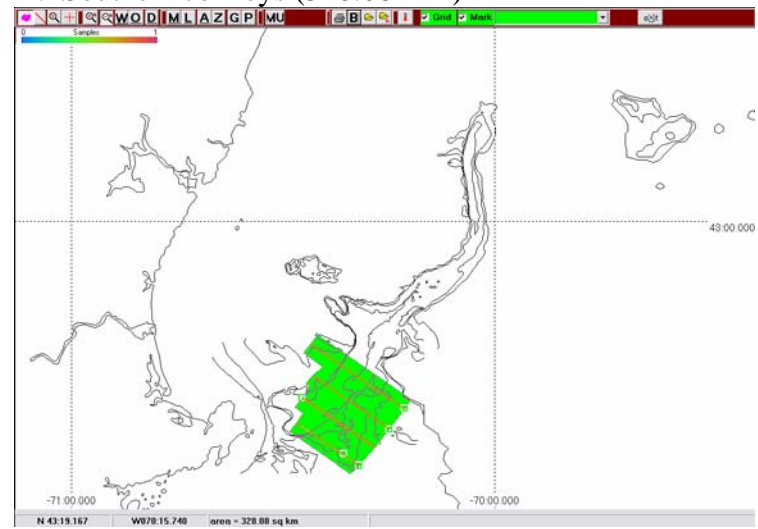
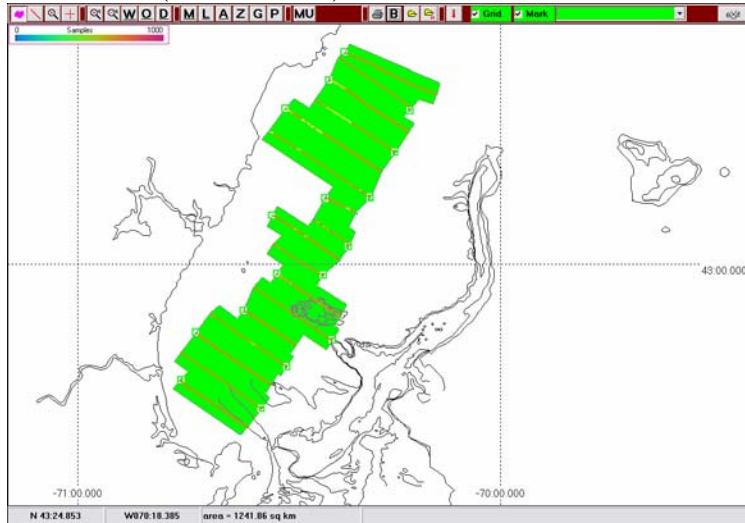

Figure 26. Sub areas used for total biomass estimate of Leg 4 (October 2 – 7).

A. Inshore (1241.86 km²)



B. Jeffreys (1653.41 km²)

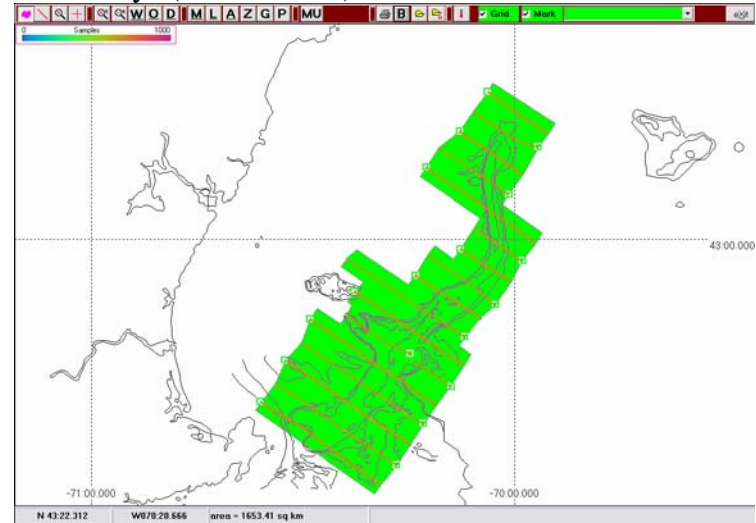
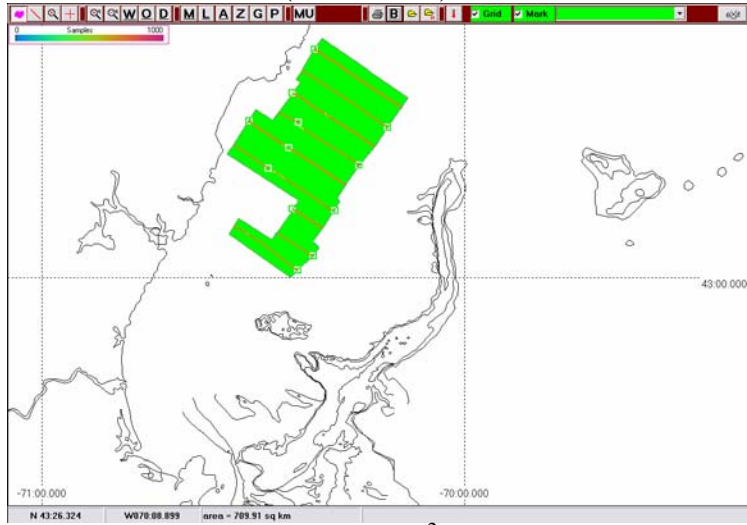
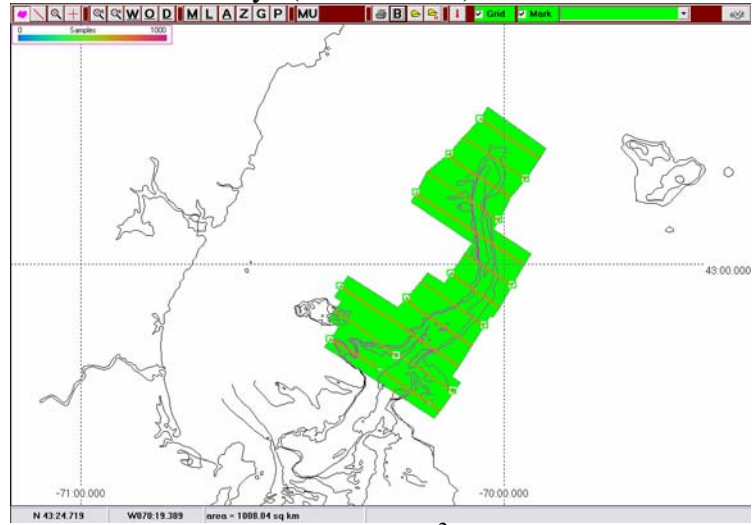

Figure 27. Sub areas used for total biomass estimate of Leg 5 (October 16 – 20).

A. Northern Inshore (709.91 km²)



B. Northern Jeffreys (1008.04 km²)



C. Southern Inshore (579.73 km²)

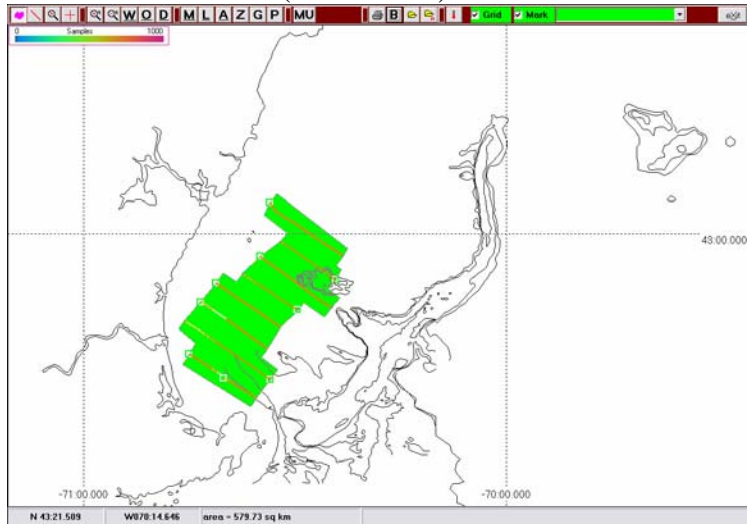

D. Southern Jeffreys (678.39 km²)

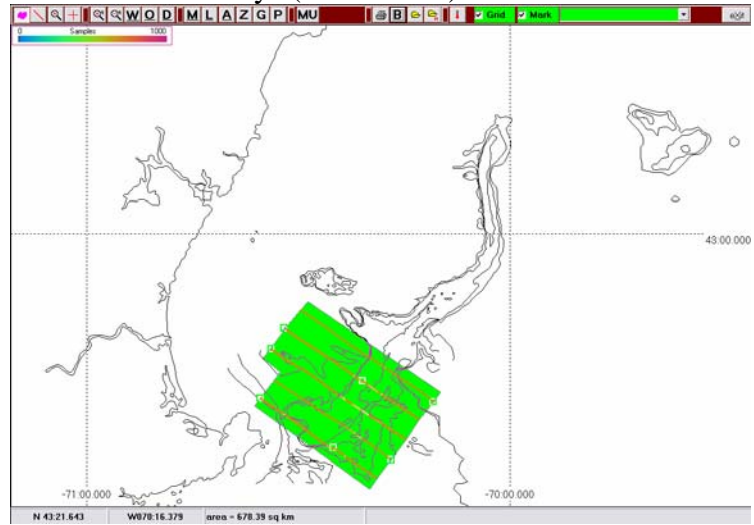
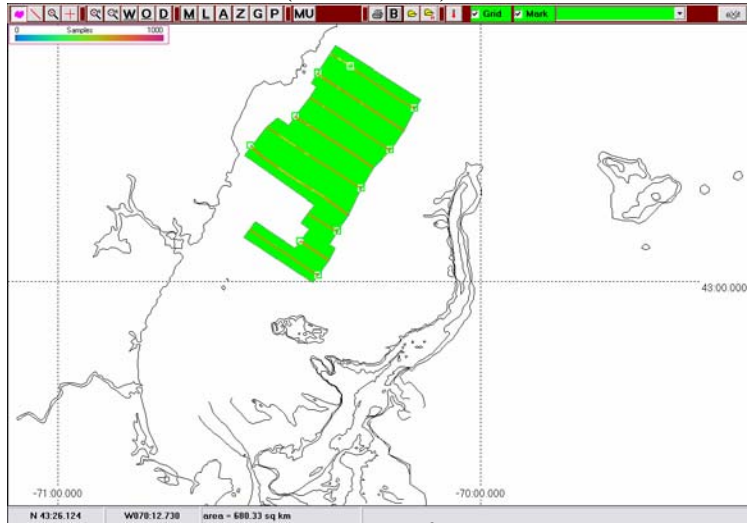
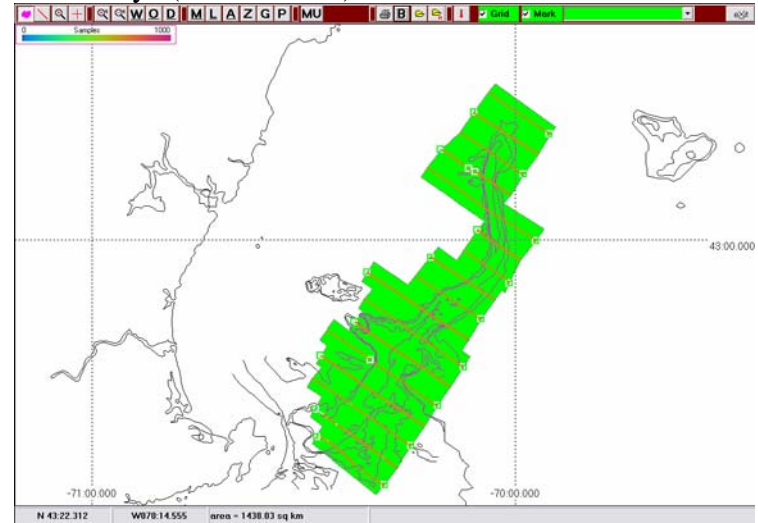

Figure 28. Sub areas used for total biomass estimate of Leg 6 (October 23 – 28).

A. Northern Inshore (608.33 km²)



B. Jeffreys (1438.03 km²)



C. Southern Inshore (813.47 km²)

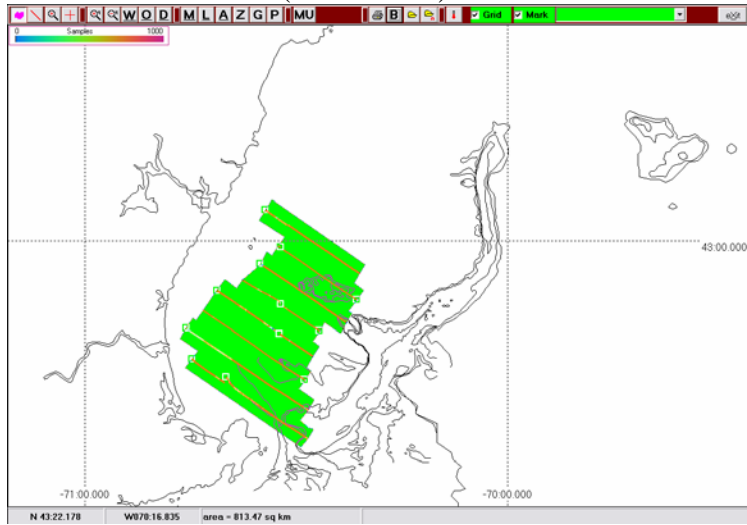
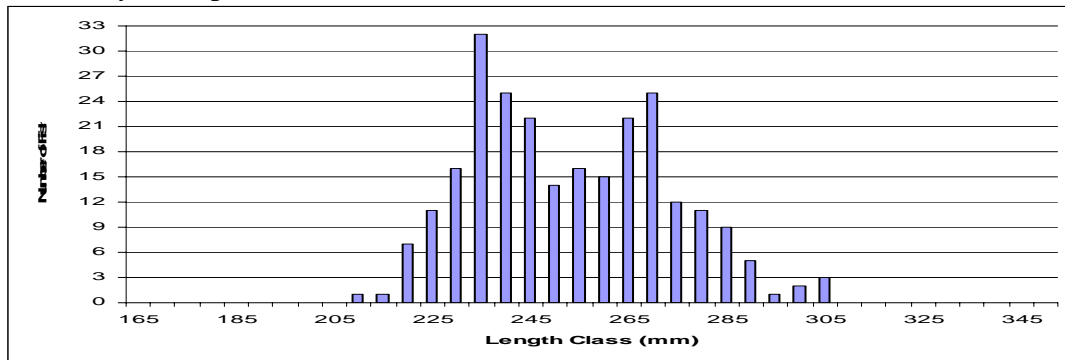
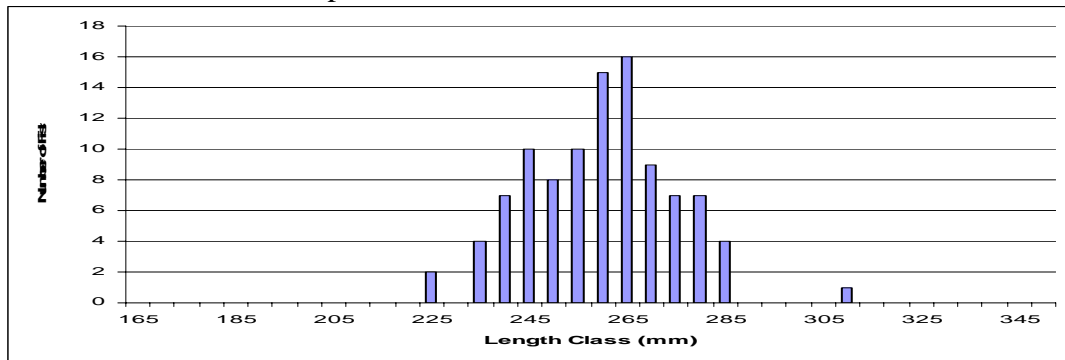

Figure 29. Sub areas used for total biomass estimate of Leg 7 (October 30 – November 3).

A. Jeffreys Sample



B. Northern Inshore Sample



C. Southern Inshore Sample

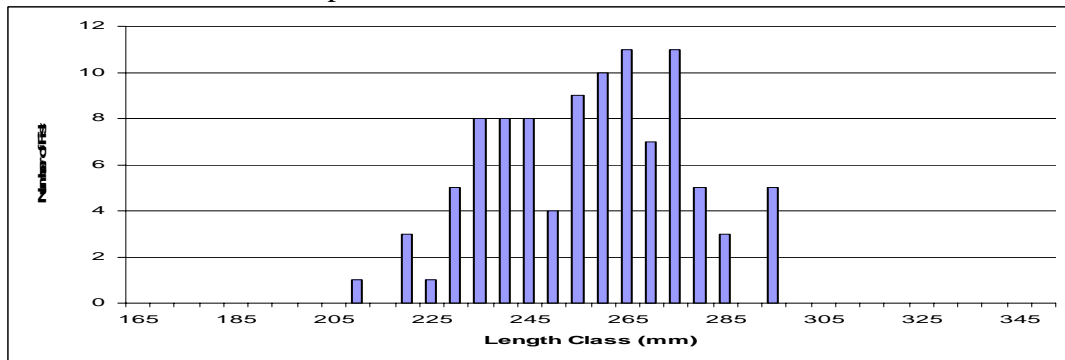
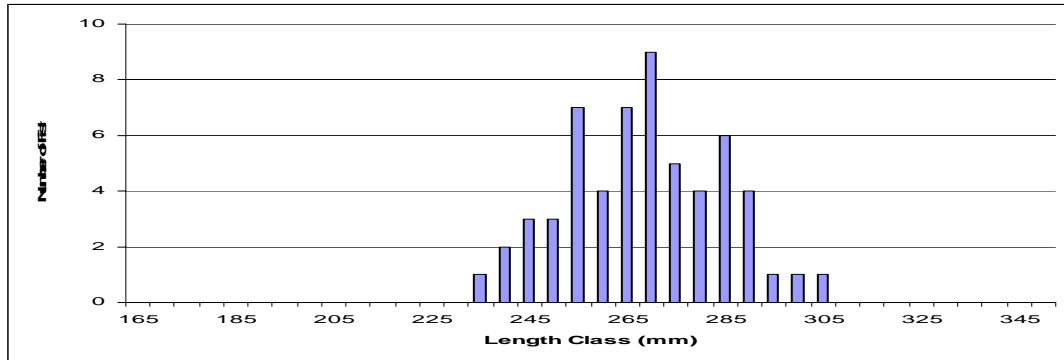
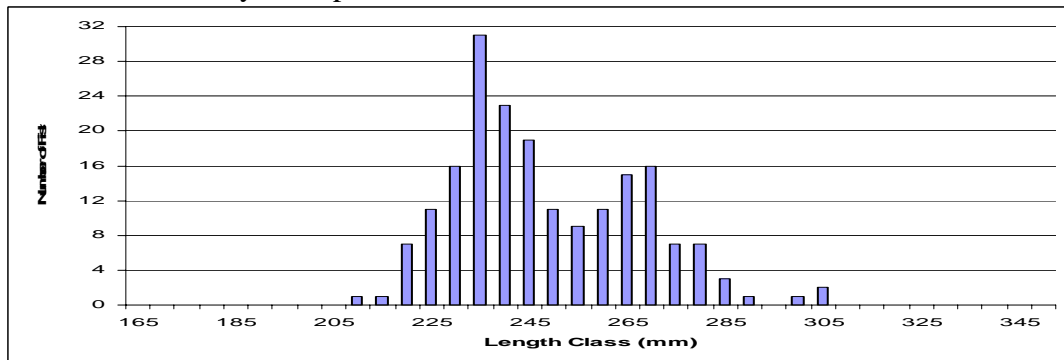

Figure 30. Length frequency distribution of Atlantic herring by sub area for Leg 1 (August 21 – 26). (Note samples from Leg 2.)

A. Northern Jeffreys Sample



B. Southern Jeffreys Sample



C. Northern Inshore Sample

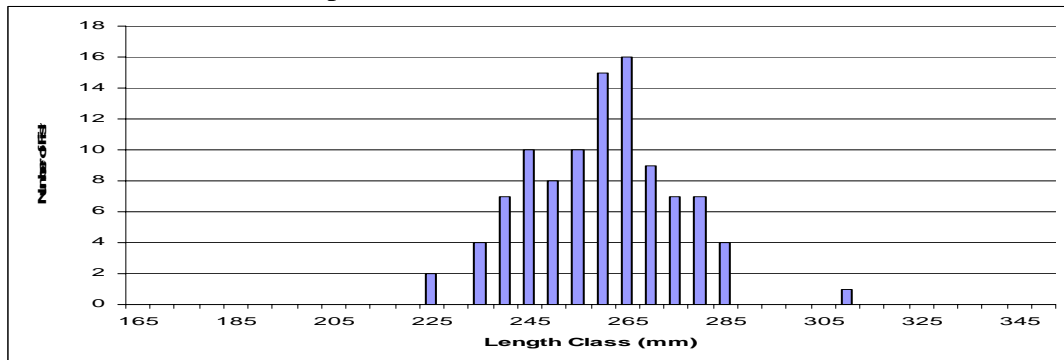

D. Southern Inshore Sample

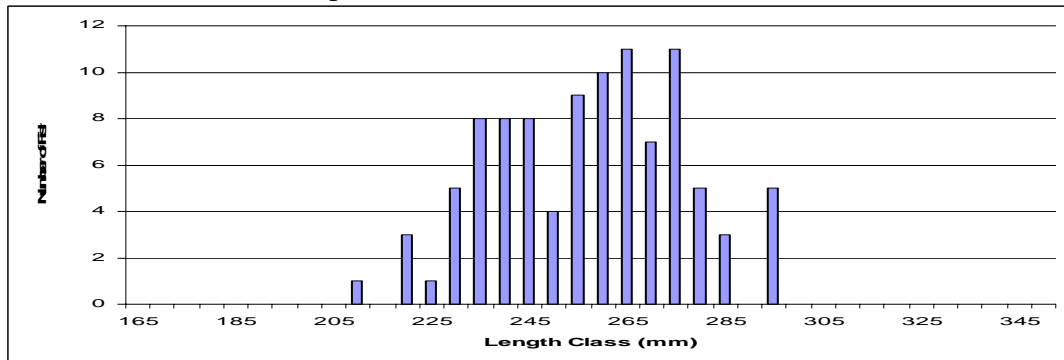
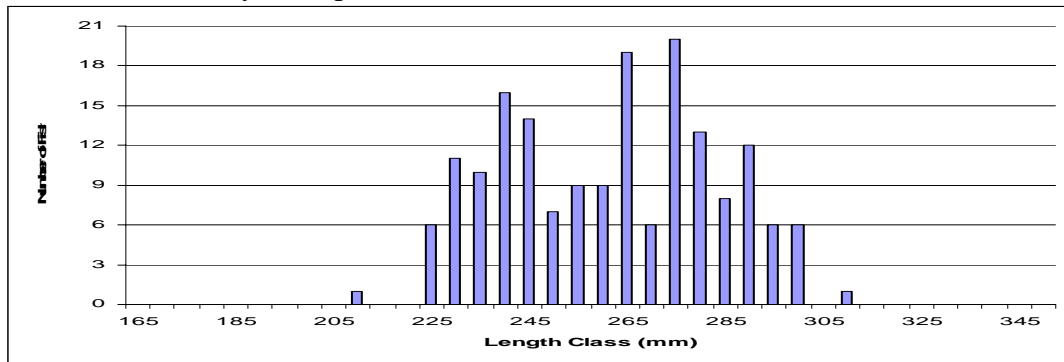
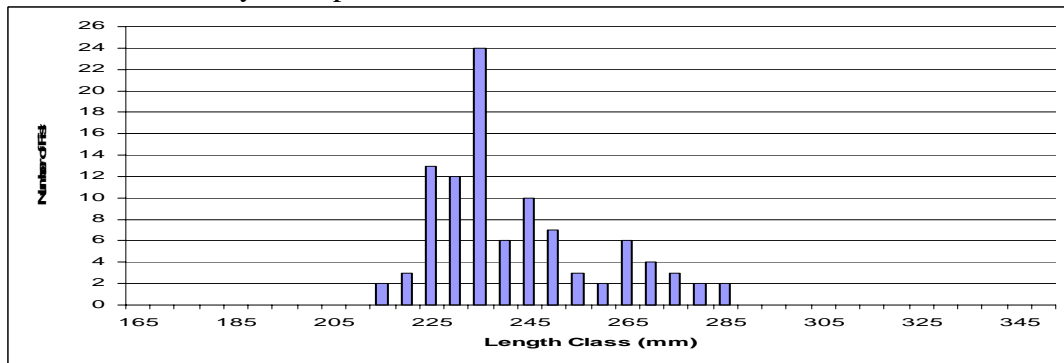

Figure 31. Length frequency distribution of Atlantic herring by sub area for Leg 2 (September 5 – 10).

A. Northern Jeffreys Sample



B. Southern Jeffreys Sample



C. Inshore Sample

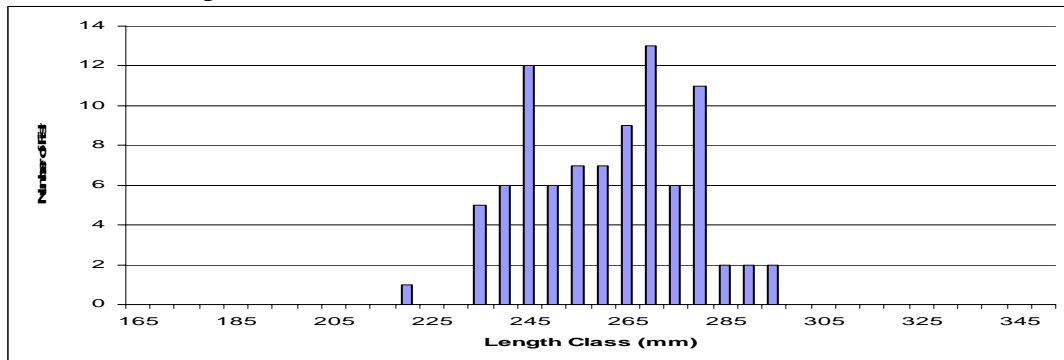
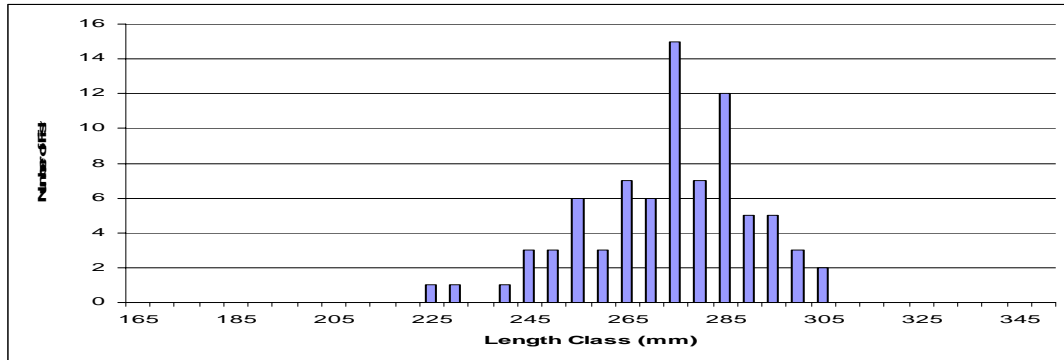
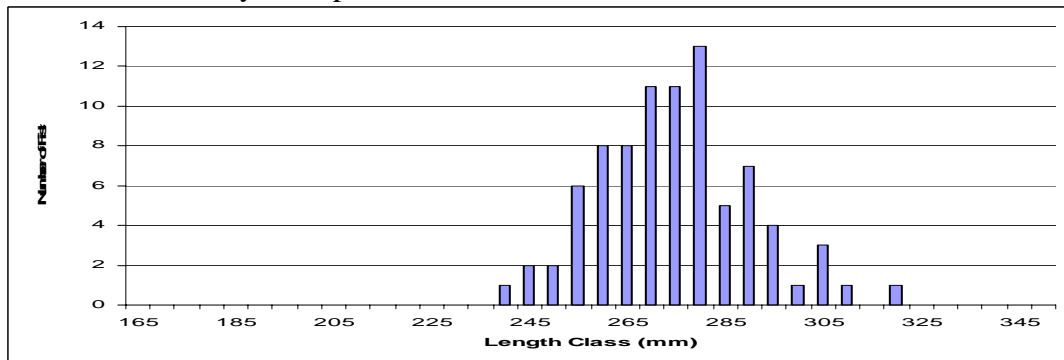

Figure 32. Length frequency distribution of Atlantic herring by sub area for Leg 3 (September 18 – 23).

A. Northern Jeffreys Sample



B. Southern Jeffreys Sample



C. Northern Inshore Sample

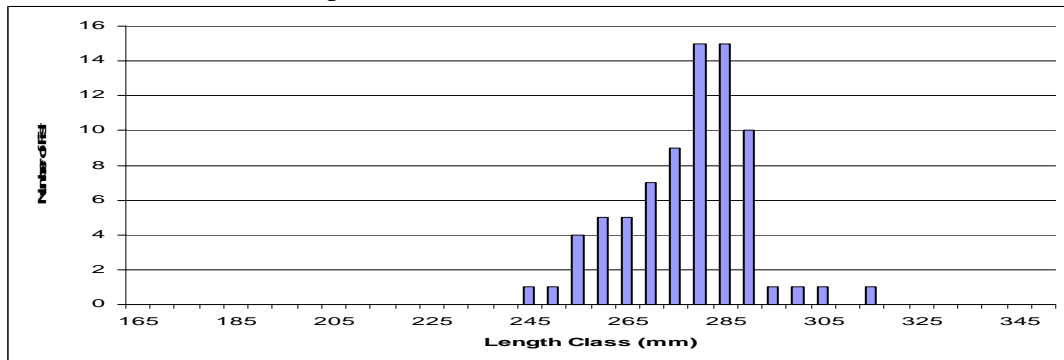

D. Southern Inshore Sample

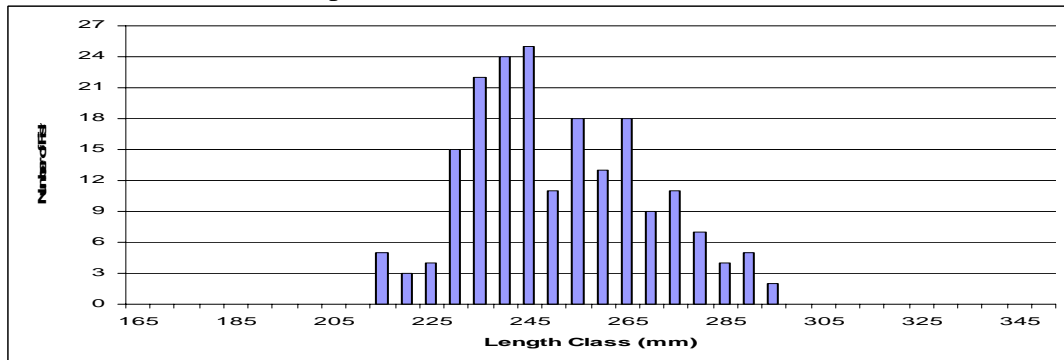
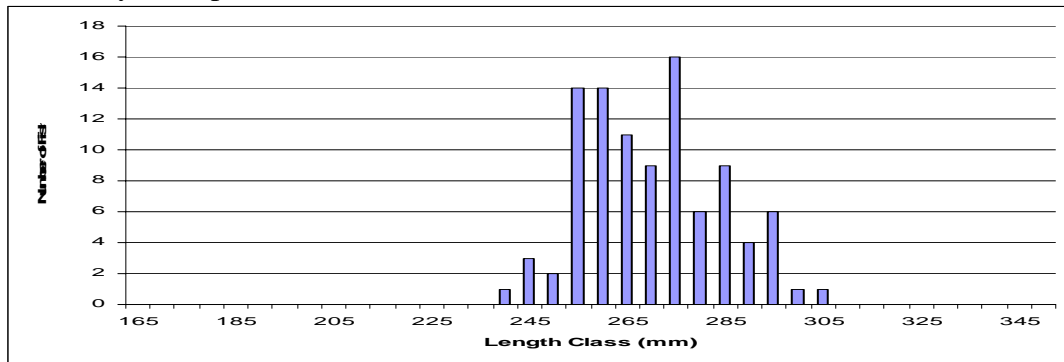

Figure 33. Length frequency distribution of Atlantic herring by sub area for Leg 4 (October 2 – 7).

A. Jeffreys Sample



B. Inshore Sample

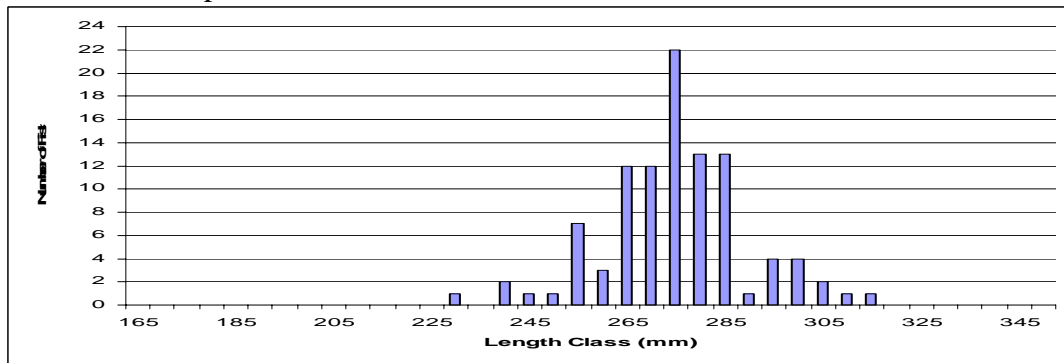
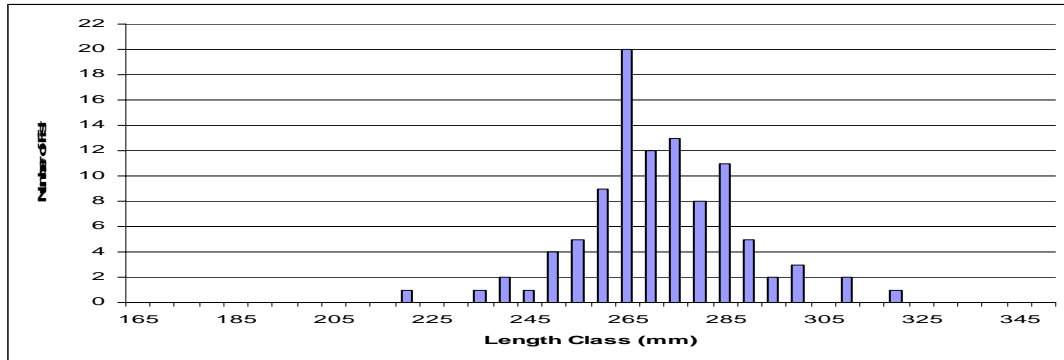
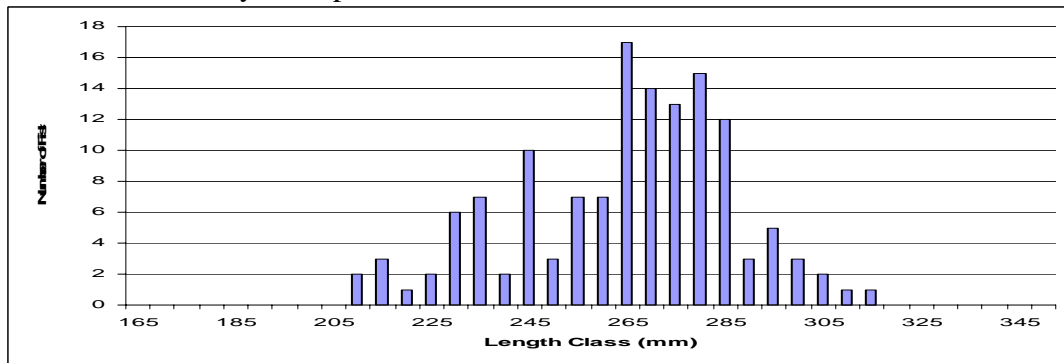

Figure 34. Length frequency distribution of Atlantic herring by sub area for Leg 5 (October 16 – 20).

A. Northern Jeffreys Sample



B. Southern Jeffreys Sample



C. Northern Inshore Sample

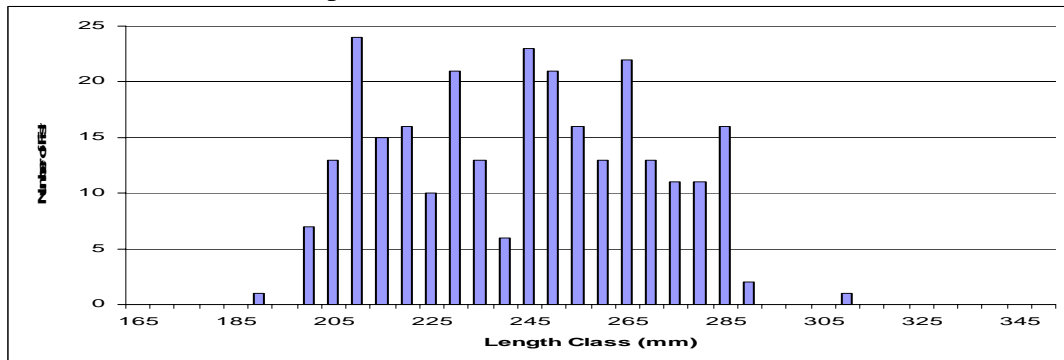

D. Southern Inshore Sample

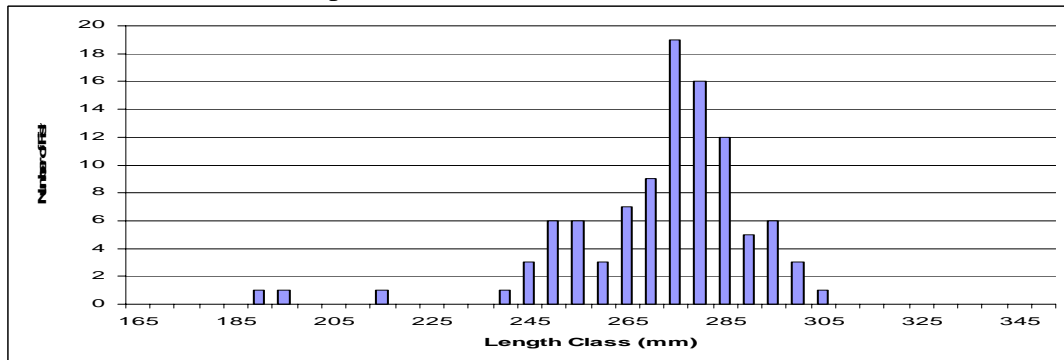
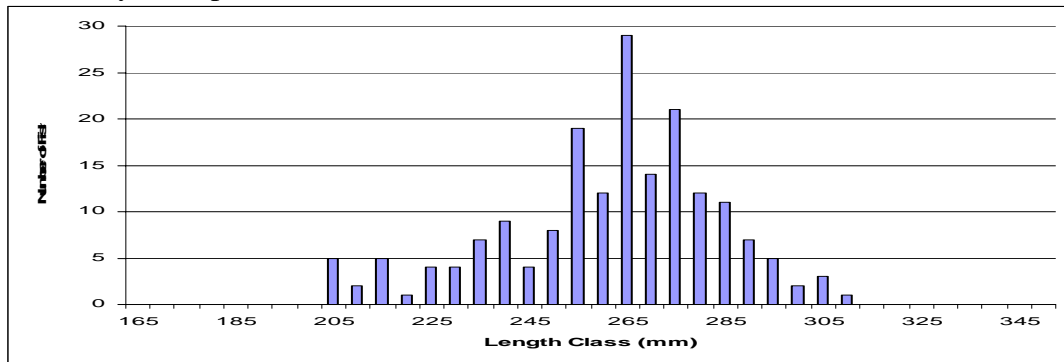
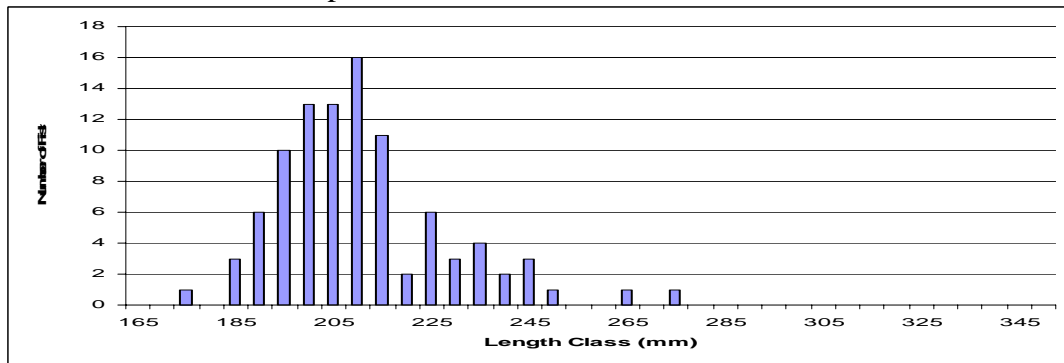

Figure 35. Length frequency distribution of Atlantic herring by sub area for Leg 6 (October 23 – 28).

A. Jeffreys Sample



B. Northern Inshore Sample



C. Southern Inshore Sample

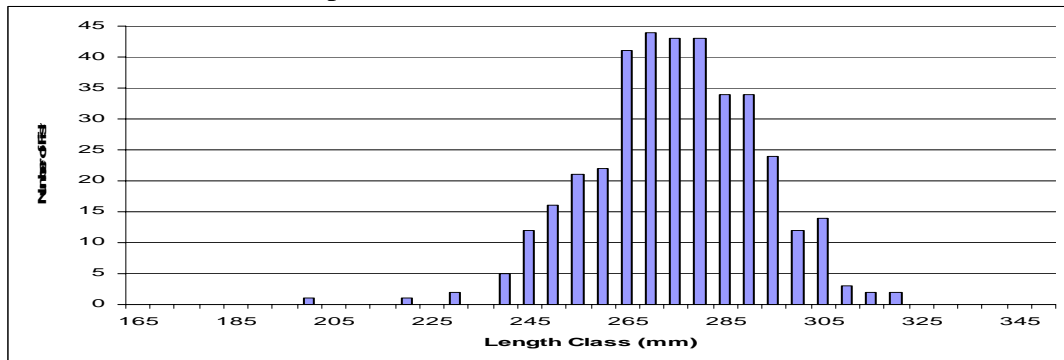

Figure 36. Length frequency distribution of Atlantic herring by sub area for Leg 7 (October 30 – November 3).

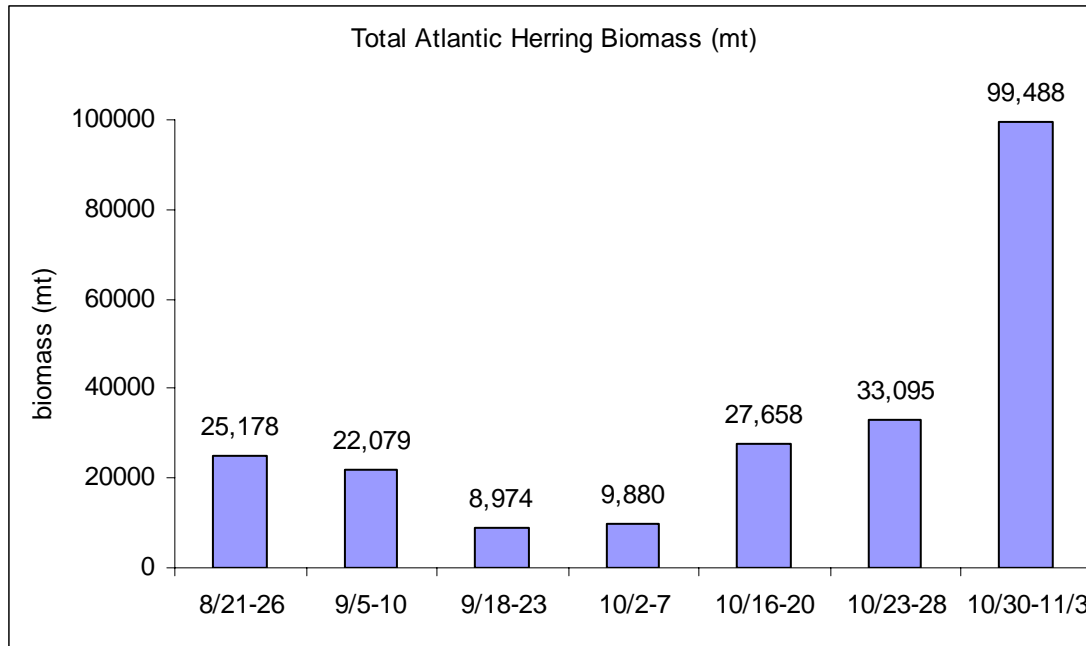
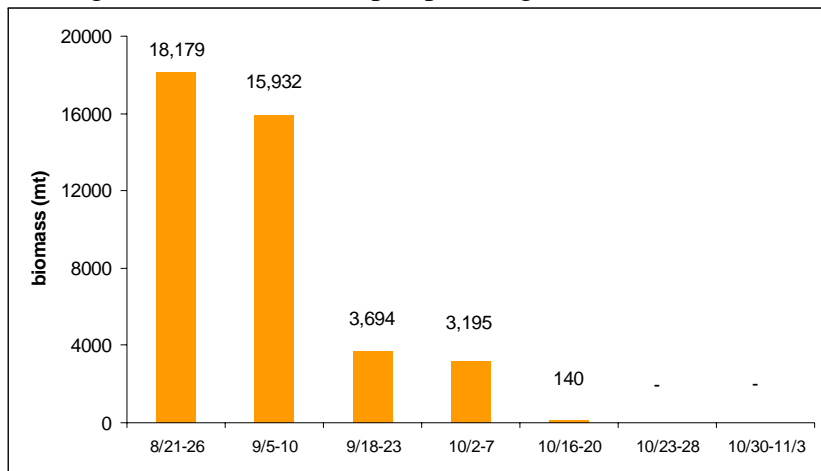
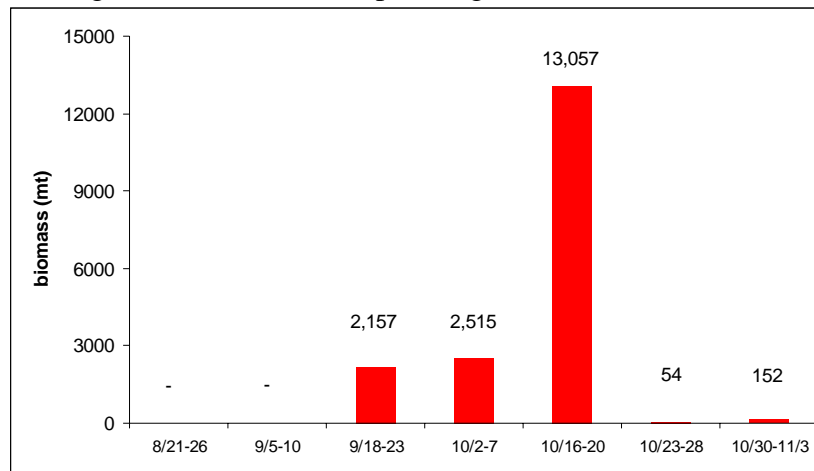

Figure 37. Total Atlantic herring biomass estimates for each survey leg.

A. Stage III & IV Biomass (prespawning)



B. Stage V & VI Biomass (spawning)



C. Stage VII & VIII Biomass (post spawning)

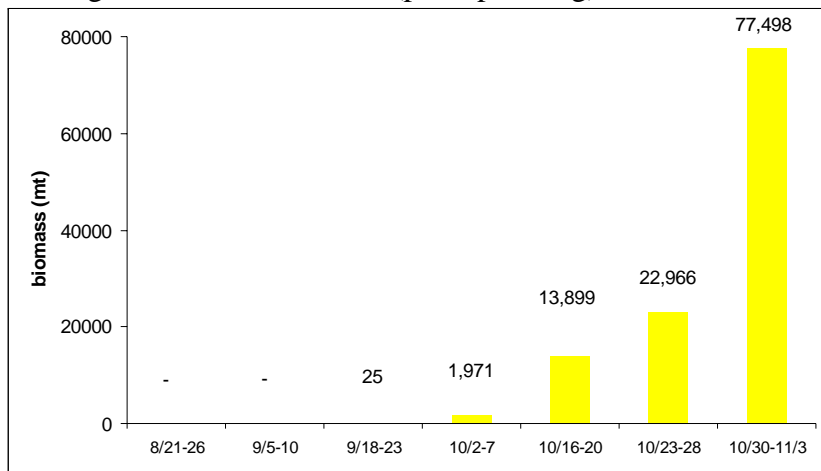

Figure 38. Atlantic herring biomass by adult maturity stage for each survey leg.

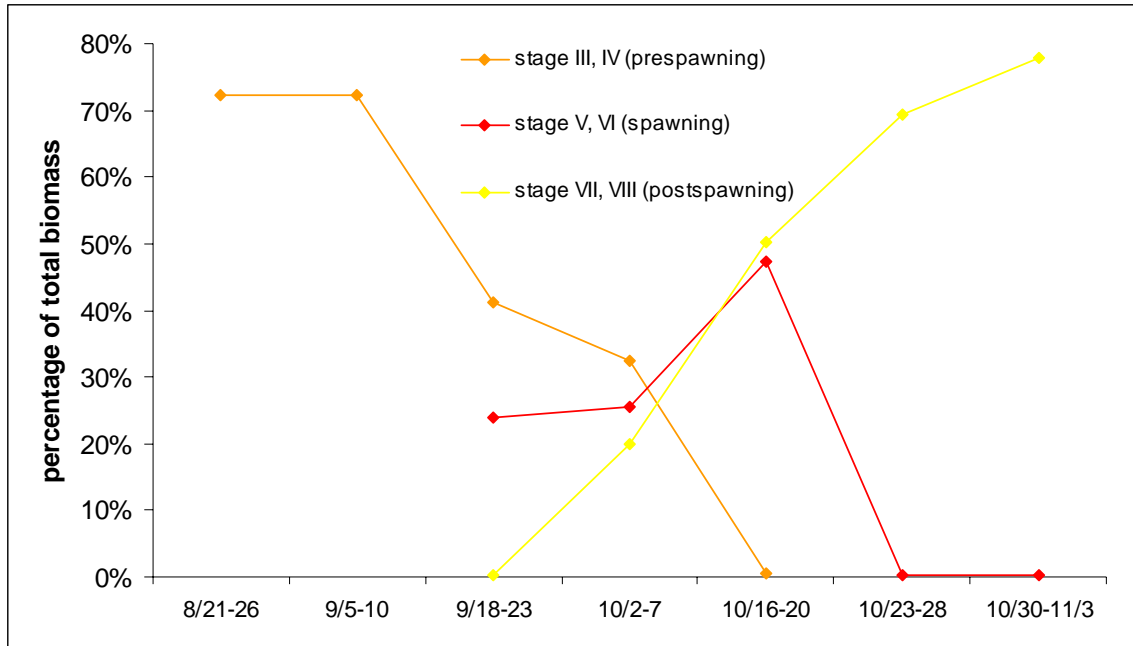

Figure 39. Percentage of total biomass by adult maturity stage for each survey leg.

